



www.ideasgroupdesign.com

IDEAS GREEN

Vegetación preservada · Preserved vegetation

IDEAS GREEN

Vegetación NATURAL para interiores **sin mantenimiento**

Con la inestimable colaboración de artesanos expertos en la materia, presentamos nuestra línea de **vegetación NATURAL estabilizada**. Un tipo de vegetación específica para ambientes interiores que no requiere mantenimiento ni luz natural o artificial.

Con este tipo de vegetación creamos escenografías naturales en cualquier tipo de espacios interiores, revistiendo paredes o techos, incorporando **NATURALEZA** donde hasta ahora era impensable hacerlo.

No se trata solo de interiorismo vegetal. Vamos mucho más allá que el aspecto estrictamente decorativo. También se trata de conexión con la **NATURALEZA**.

El diseño **biofílico**, consistente en la integración de la naturaleza en espacios interiores para proporcionar bienestar a las personas, favorece aspectos como: reducción del estrés, mayor confort acústico, propicia el buen ánimo, mejora la convivencia, aumenta la productividad, etc..

En resumen, creamos oasis de confort, bienestar y relajación para el desempeño de labores domésticas, profesionales u ocio, de forma más eficaz.



NATURAL indoor vegetation **without maintenance**

With the invaluable collaboration of skilled craftsmen in the field, we present our **stabilized NATURAL vegetation line**. A specific type of vegetation for indoor environments that does not require maintenance or natural or artificial light.

With this type of vegetation we create natural scenery in any type of interior spaces, covering walls or ceilings, incorporating **NATURE** where until now it was unthinkable to do so.

It is not just about plant interior design. We go much further than the strictly decorative aspect. It is also about connection with **NATURE**.

Biophilic design, consisting of the integration of nature in interior spaces to provide well-being to people, favors aspects such as: stress reduction, greater acoustic comfort, promotes good mood, improves coexistence, increases productivity, etc.

In summary, we create oases of comfort, well-being and relaxation for the performance of domestic tasks, professional or leisure, more effectively.

BIOPHILIA

Connection with nature

- Jardines verticales para pared o techo
- Jardines verticales personalizados
- Jardines colgantes
- Plantas y jardineras
- Divisores de ambientes
- Identificaciones corporativas para entidades

100% made in EUROPE

- Vertical gardens for wall or ceiling
- Personalized vertical gardens
- Hanging gardens
- Plants and planters
- Space dividers
- Corporate identity for entities



ORIGIN

Qué tipo de vegetación utilizamos?

La vegetación estabilizada es **NATURAL**.

Musgos y líquenes cultivados en la zona ártica son recolectados con pleno respeto a la naturaleza siguiendo los ciclos de recolección programados, dando vida a la sostenibilidad y a los aspectos ecológicos.

El líquen tiene un aspecto 'esponjoso' y su color natural es blanquecino lo que permite darle diferentes coloración mediante pigmentos naturales.

En nuestras composiciones de VERTICAL GARDENS utilizamos varios tipos de musgos preservados, sobre todo el musgo plano y el musgo bola.

Esta diferenciación de musgos permite realizar múltiples combinaciones y posibilidades creativas, formando distintos volúmenes y texturas que consiguen recrear auténticos murales naturales.

Las flores, plantas y follaje que se cosechan en el mejor momento de su ciclo de vida cuando tienen la mejor apariencia son sometidas al proceso de estabilización.

En resumen, se trata de materias naturales que favorecen la salud de las personas.
Seguras y duraderas.
No impactan en el medioambiente.



What vegetation do we use?

The stabilized vegetation is **NATURAL**.

Mosses and lichens grown in the arctic zone are collected with full respect to nature following the scheduled collection cycles, giving life to the sustainability and ecological aspects.

The lichen has a 'spongy' appearance and its natural color is whitish which it allows to give different coloration by means of natural pigments.

In our vertical garden compositions we use various types of moss preserved, especially flat moss and ball moss.

This differentiation of mosses allows multiple combinations and creative possibilities, forming different volumes and textures that achieve recreate authentic natural murals.

Flowers, plants and foliage that are harvested at the best time in their growth cycle life when they have their best appearance are subjected to the stabilization process.

In short, these are natural materials that favor people's health.
Safe and durable.
They do not impact the environment.

ELABORATION

Qué es la estabilización?

La estabilización es un verdadero arte. Es una técnica que permite que la planta conserve su aspecto original con toda su flexibilidad, plasticidad y vigor natural sin requerir agua, luz natural ni mantenimiento posterior. Este proceso también suele ser denominado como preservación.

Se trata de un proceso totalmente ecológico que consiste en reemplazar la savia natural por una solución de conservación 100% biodegradable. Esta sustancia preservante reemplaza la savia y agua de la planta para formar una imagen estática de la naturaleza creando un producto sin igual **100% natural**.

Los productos químicos utilizados en este proceso no son tóxicos, ni explosivos, corrosivos, cancerígenos o químicamente reactivos y, por lo tanto, no representan una amenaza para la salud humana o el medio ambiente.

Una vez estabilizado, el material se selecciona cuidadosamente a mano durante la fase de control de calidad para ser colocado durante la fabricación de nuestros VERTICAL GARDENS.



What is stabilization?

Stabilization is a true art. It is a technique that allows the plant to preserve its original appearance with all its flexibility, plasticity and natural vigor without requiring water, natural light or subsequent maintenance. This process is also often referred to as preservation.

It is a totally ecological process that consists of replacing the natural sap with a 100% biodegradable conservation solution. This preservative substance replaces the sap and water of the plant to form a static image of nature, creating an unparalleled **100% natural** product.

The chemicals used in this process are not toxic, explosive, corrosive, carcinogenic or chemically reactive and therefore do not pose a threat to human health or the environment.

Once stabilized, the material is carefully selected by hand during the quality control phase to be placed during the manufacture of our vertical gardens.



Characteristics



100%
natural



Minimum humidity
35%



Custom
sizes



Long
duration



Flexible
and
adaptable



Interiors
Spaces



Sustainable
environment



Not attract
insects



Antibacterial



Not load
electrostatic.
Does not attract
dust



Without
Maintenance



Not need
natural light



Not expose to
sunlight



Flame retardant
(Moss version)

UNI EN 13501 + A1:2013
(Class B-s2, d0)
y ASTM E84-17
(Class A)



Sound absorbance

Tested for ASTM C423 NRC
0,30 SAA 0,31



Easy
install



Non-allergenic



not emit
Co2



Minimum
guarantee
2 years

PROPIEDAD FONOAORBENTE



SOUND-ABSORBING PROPERTIES

Nuestros jardines verticales o de techo tienen **propiedades fonoabsorbentes** que ayuda a reducir la reverberación en el ambiente.

Como es sabido, en los espacios donde se congregan varias persona durante un tiempo determinado suele producirse una acumulación de ondas sonoras que dificultan el entendimiento y, si este es excesivo, puede incluso resultar nocivo para la salud de las personas.

Por ejemplo en oficinas ... salas de espera ... escuelas ... restaurantes ... bares ... tiendas comerciales ...

Debido al espesor de la vegetación (aproximadamente 2 / 3 / 4 cm. dependiendo de la versión) y la abundancia de hojas que componen el jardín, permite que las ondas sonoras penetren y no “reboten” hacia el exterior, evitando así lo que se denomina reverberación.

Por lo tanto, con la instalación de nuestros **jardines verticales o de techo** creamos entornos más acogedores proporcionando **BIENESTAR y SALUD** para las personas:

DECORACIÓN NATURAL
NATURAL DECORATION



MEJORA EMOCIONAL
EMOTIONAL IMPROVEMENT



CONFORT ACÚSTICO
ACOUSTIC COMFORT

Our vertical or roof gardens have **sound-absorbing properties** that help reduce reverberation in the room.

As is well known, in spaces where several people congregate for a certain time, there is usually an accumulation of sound waves that make understanding difficult and, if this is excessive, it can even be harmful to people's health.

For example in offices ... waiting rooms ... schools ... restaurants ... bars ... commercial stores ...

Because to the thickness of the vegetation (approximately 2 / 3 / 4 cm depending on the version) and the abundance of leaves that make up the garden, it allows sound waves to penetrate and not "bounce" outwards, thus avoiding what is called reverberation.

So, with the installation of our **vertical or ceiling gardens** we create more welcoming areas providing **WELL-BEING and HEALTH** for the people:

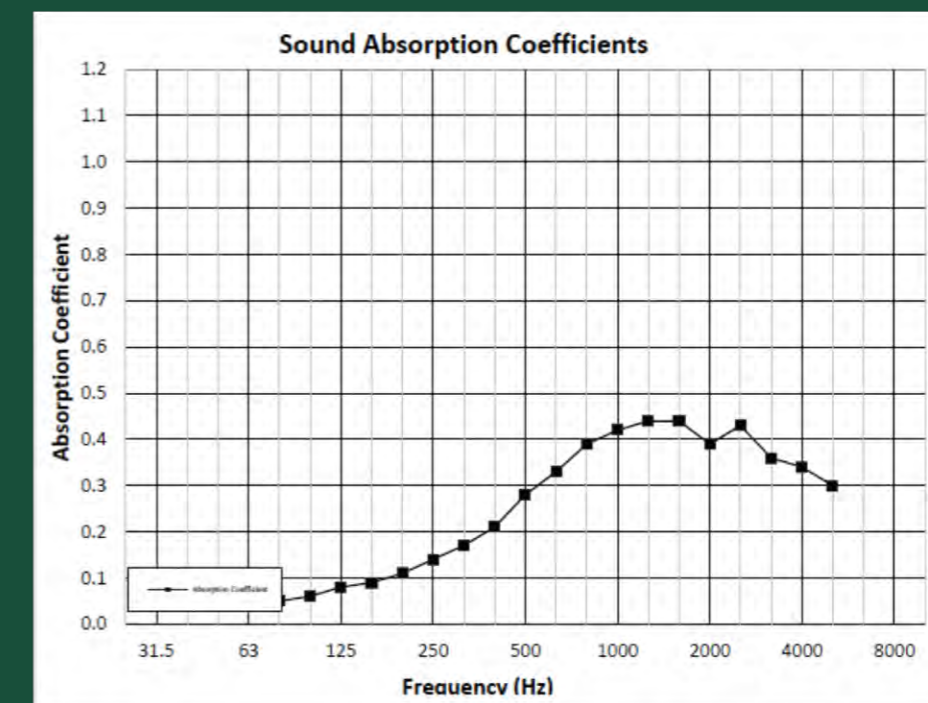

Advantages

- Producto **NATURAL** con todos los beneficios de bienestar y salud.
La integración de elementos **NATURALES** en espacios interiores revolucionan por completo el concepto del medio ambiente circundante con una ventaja incalculable sobre la salud de las personas que lo habitan y sobre la calidad del trabajo que desempeñan.
- **Mejora la acústica**, nuestros jardines absorben el sonido de forma natural, amortiguando y reduciendo el ruido ambiental favoreciendo la creación de espacios interiores más confortables.
Certificado ASTM C423 NRC 0.30 SAA 0.31.
La contaminación acústica en los centros de trabajo provoca poca concentración, niveles reducidos de colaboración, aumento del estrés e incomodidad, dando como resultado una menor productividad.
- **No requiere instalación** de sistema de riego automático y desagüe de agua con el consiguiente ahorro económico
- **No requiere mantenimiento** con el consiguiente ahorro económico (riego ... poda ... limpieza ...)
- **Producto Ignífugo**
Certificación UNI EN 13501 + A1: 2013 (Clase B-s2, d0) y ASTM E 84-17 (Clase A)
- **NATURAL** product with all the benefits of wellness and health.
The integration of **NATURAL** elements in interior spaces completely revolutionizes the concept of the surrounding environment with an incalculable advantage over the health of the people who inhabit it and over the quality of the work they perform.
- **Improves acoustics**, our gardens absorb sound naturally, cushioning and reducing ambient noise, favoring the creation of more comfortable interior spaces.
Certificate ASTM C423 NRC 0.30 SAA 0.31
Noise pollution in the workplace causes poor concentration, reduced levels of collaboration, increased stress and discomfort, resulting in lower productivity.
- **Does not require installation** of automatic irrigation and drainage system of water with the consequent economic savings
- **Does not require maintenance** with the consequent economic savings (watering... pruning... cleaning...)
- **Fire retardant**
Certification UNI EN 13501 + A1: 2013 (Class B-s2, d0) and ASTM E 84-17 (Class A)

• Producto biodegradable

• Fácil instalación

Soporte en DM o aluminio (según modelo)



Flexible para adaptarse a cualquier pared, techo o columna



• Biodegradable product

• Easy installation

Support in mdf or aluminum (according to model)



Flexible for adapt to any wall, roof or column



te ofrecemos..



we offer you...

PROYECTOS A MEDIDA

Todos nuestros jardines naturales estabilizados se fabrican a la medida solicitada por el cliente.

GAMA

Tenemos una amplia variedad de vegetación NATURAL estabilizada para VERTICAL GARDENS, plantas, paneles a pared, iluminación, divisores de ambientes, artículos purificadores de aire y complementos para satisfacer distintas necesidades y crear espacios interiores más sanos.

DISEÑOS PERSONALIZADOS

Máxima libertad y flexibilidad para proyectar espacios VERDES personalizados.

ASESORAMIENTO CREATIVO

Somos creativos.

Ofrecemos soluciones a las necesidades de incorporar naturaleza en los espacios residenciales, comerciales, ocio, etc..

ASESORAMIENTO TÉCNICO

Somos técnicos.

Ofrecemos soluciones para resolver cualquier situación que se presente para incorporar nuestros VERTICAL GARDENS.

INTERIORISMO

No solo integramos **NATURALEZA** en los espacios interiores habitables.

También aportamos interiorismo.

Nuestras creaciones resultan escenografías vegetales para interiores.

Creamos composiciones monocolor o multicolor a elección del cliente.

Combinamos diversa tipología de plantas preservadas, diferente volúmenes, formas, etc..

Hasta donde llegue la imaginación de cada cliente.

CUSTOMIZED PROJECTS

All our stabilized natural gardens are manufactured to the extent requested by the client.

RANGE OF ITEMS

We have a wide variety of stabilized NATURAL vegetation to vertical gardens, plants, wall panels, lighting, room dividers spaces, air purifying items and accessories to satisfy different needs and create healthier interior spaces.

CUSTOM DESIGNS

Maximum freedom and flexibility to design personalized GREEN spaces

CREATIVE ADVICE

We are creative.

We offer solutions to the needs of incorporating nature in residential, commercial, leisure spaces, etc.

TECHNICAL ADVICE

We are technicians.

We offer solutions to solve any situation that arises to incorporate our vertical gardens.

INTERIOR DESIGN

We not only integrate NATURE in the interior living spaces.

We also provide interior design.

Our creations turn out to be vegetable scenographies for interiors.

We create monocolor or multicolor compositions at the customer's choice.

We combine different types of preserved plants, different volumes, shapes, etc.

As far as the imagination of each client.

COLOURS



GRASS



FOREST



VERDE
GRANOZZO



OCEAN



SEA MIST new



CREAM



SUNSHINE



SUNSET



BLUE



FUXIA



RED new



CITY



Colección MOSS

En la naturaleza incontaminada de los bosques de Laponia, el Liqueen Reno (*Cladonia Stellaris*) crece en áreas protegidas garantizando el ecosistema natural de la "tierra del hielo".

El musgo (Moss), polemos y líquenes se cultivan en áreas especiales, se recolecta, se seca y posteriormente se someten a un proceso de estabilización (preservación) mediante sólo sustancias naturales.

Este particular proceso de estabilización se realiza en el mejor momento de su ciclo de vida, mediante la sustitución de la savia por un producto 100% biodegradable a base de glicerina natural y agua que permite que se mantengan perfectamente e inalterables durante más de 10 años.



In the uncontaminated nature of the Lapland forests, the Reindeer Lichen (*Cladonia Stellaris*) grows in protected areas guaranteeing the natural ecosystem of the "land of ice".

The moss, polemos and lichens are cultivated in special areas, collected, dried and subsequently subjected to a stabilization (preservation) process using only natural substances.

This particular stabilization process is carried out at the best moment of its life cycle, by replacing the sap with a 100% biodegradable product based on natural glycerin and water that allows it to remain perfectly and unalterable for more than 10 years.



FLAT MOSS



POLEMOSS



LICHEN

MOSS

Revestimiento de vegetación estabilizada con cobertura total 100% líquen natural preservado en 12 colores.

Colores de serie: Grass - Forest.
Para otros colores: bajo presupuesto.

Soporte en DM para superficies planas.

Soporte en PVC flexible para superficies curvas o para proyectos con necesidad de material ignífugo



Stabilized vegetation lining with 100% total coverage preserved natural lichen in 12 colours.

Serial colours: Grass – Forest.
Other colours: by budget.

MDF support for flat surfaces.

Flexible PVC support for curved surfaces or for projects requiring fireproof material.



GRASS



FOREST



10 colores
10 colours





adidas







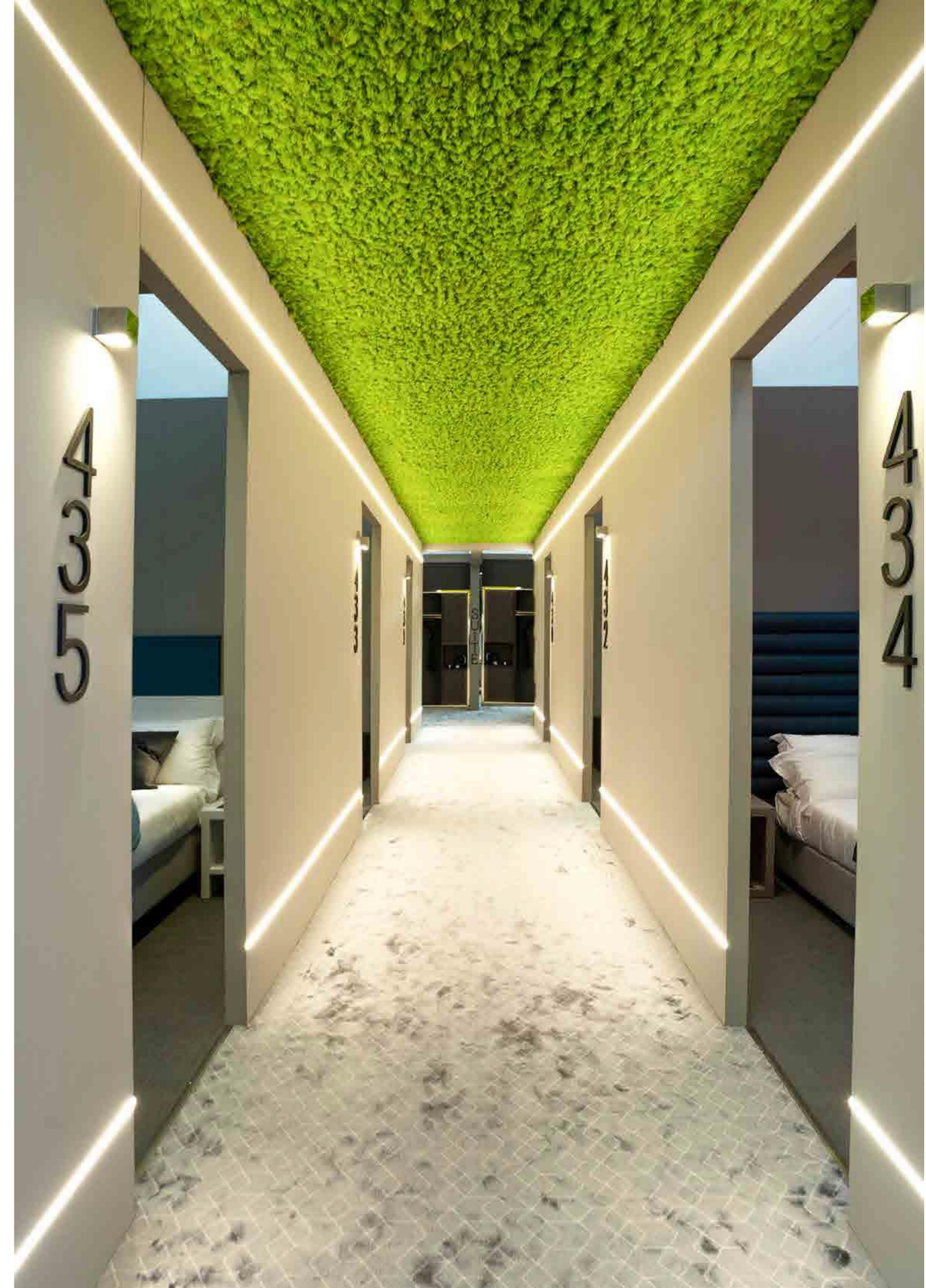

MOSS MIX

Revestimiento de vegetación estabilizada con cobertura total 100% líquen natural preservado combinando colores de verde: CAMUFLAGE o GREEN MIX.

Stabilized vegetation cladding with total coverage 100% preserved natural lichen combining green colors: MILITAR or MIX GREEN.



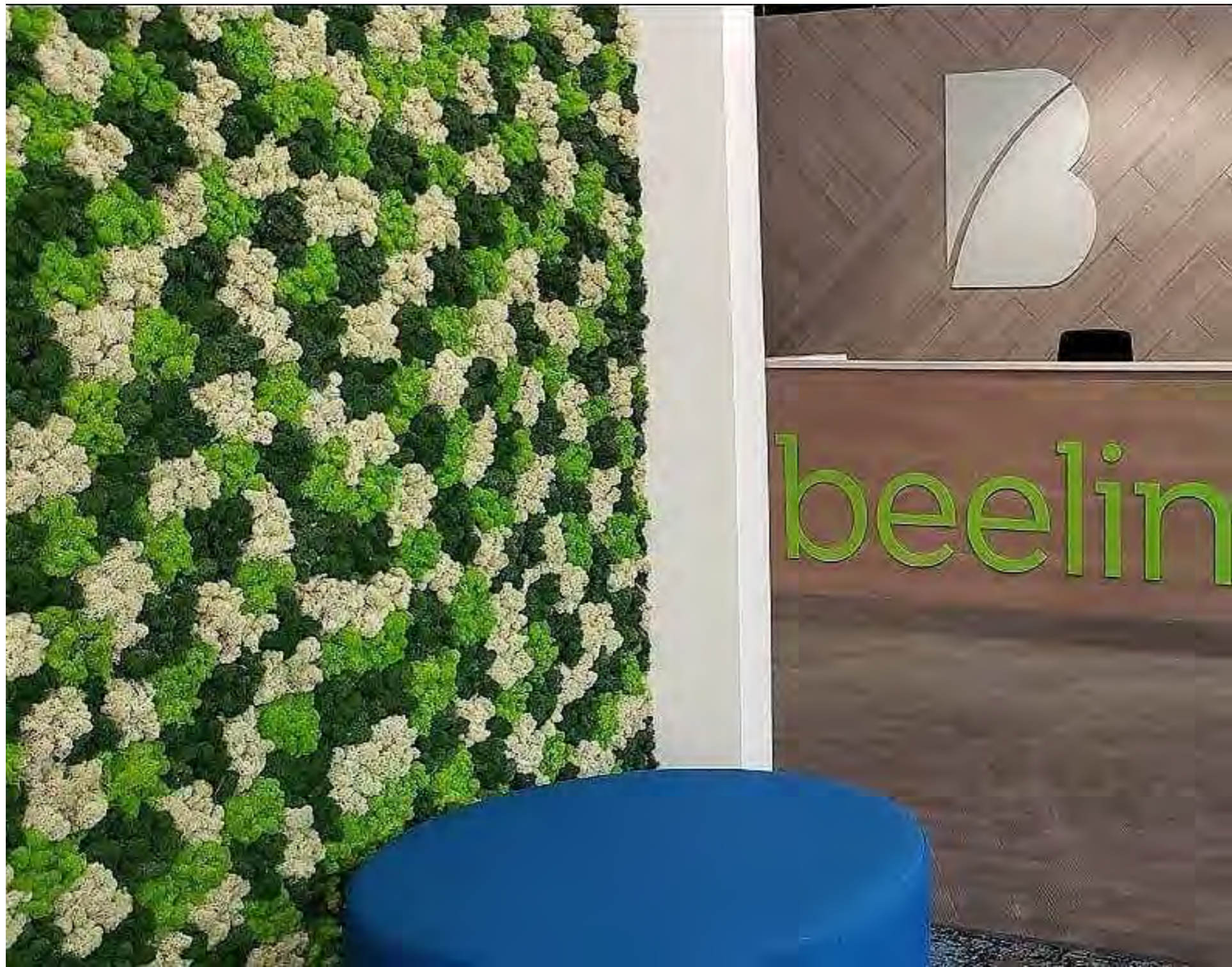



MOSS BUBBLE

Revestimiento de vegetación estabilizada con efecto tridimensional de líquen natural conservado en 10 colores.

Panel de 5 semiesferas de diferentes tamaños en cada panel para combinar con paneles Moss.

Stabilised vegetation cladding with three-dimensional effect of preserved natural lichen in 10 colours. Panel of 5 hemispheres of different sizes in each panel to combine with Moss panels.

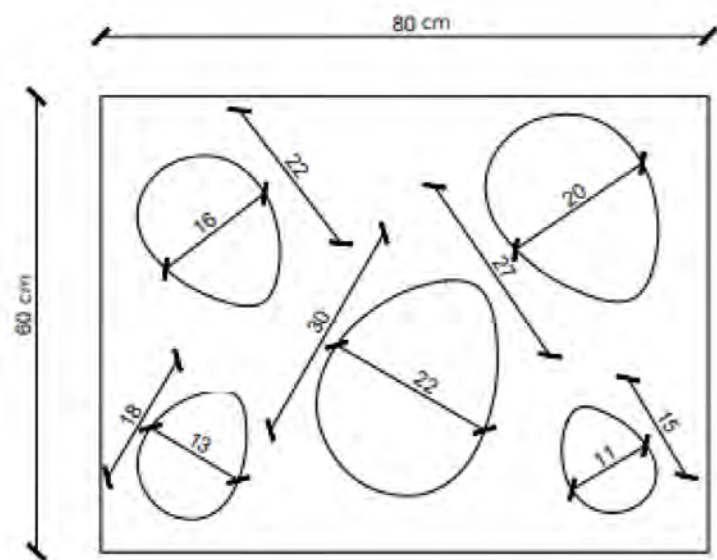

MOSS NIAGARA

Revestimiento de vegetación estabilizada con cobertura total 100% líquen natural preservado compuesto de Flat Moss + At-MOSSsphere

Stabilised vegetation cover with full coverage 100% natural preserved lichen composed of Flat Moss + At-MOSSsphere





IVATO

REVERGREEN

REVERGREEN

REVERGREEN



MOSS MALESIA

Revestimiento de vegetación estabilizada con cobertura total 100% líquen natural preservado compuesto de Flat Moss + Moss + At-MOSSsphere

Stabilised vegetation cover with full coverage 100% natural preserved lichen composed of Flat Moss + Moss + At-MOSSsphere



SPRING

Revestimiento de vegetación estabilizada con cobertura con base de líquenes con inserción de otras plantas preservadas (hiedra, amarantos, helechos y otras).

Soporte en pvc flexible apto para superficies planas y curvas.
Escenografía equivalente a jardines vivos.

Covering of stabilized vegetation with cover based on lichens with insertion of other preserved plants (ivy, amaranths, ferns and others).

Flexible PVC support suitable for flat and curved surfaces.
Scenery equivalent to living gardens.

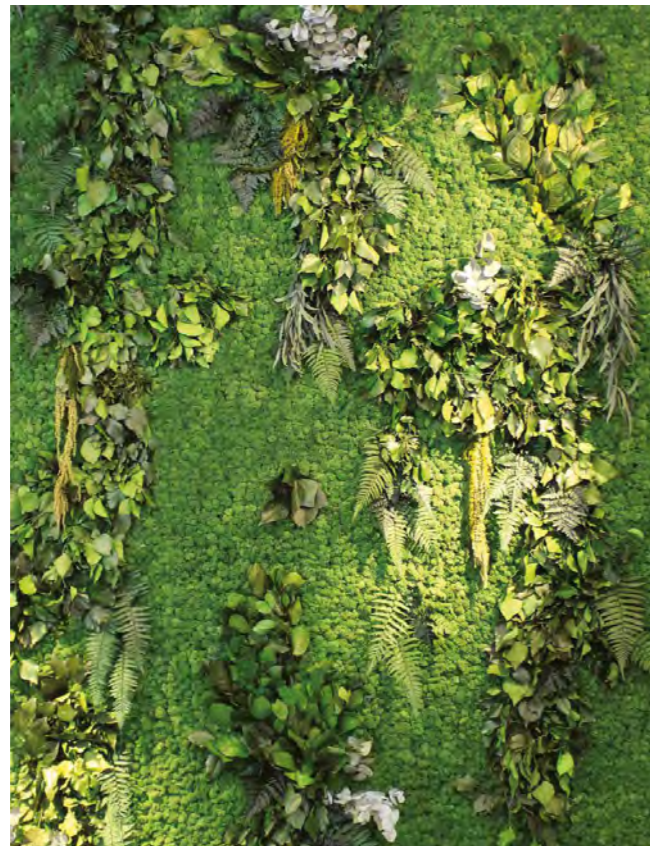

900 Culver Pointe





JAVA

Revestimiento de vegetación estabilizada con cobertura total 100% de plantas con base de hiedra e inserción de otras plantas preservadas (helechos, eucaliptos, salal, pittosporum).

Soporte en pvc flexible apto para superficies planas y curvas.
Escenografía equivalente a jardines vivos.

Stabilized vegetation lining with 100% total coverage of ivy-based plants and insertion of other preserved plants (ferns, eucalyptus, salal, pittosporum).

Flexible PVC support suitable for flat and curved surfaces.
Scenery equivalent to living gardens.





NR

NR
DIGITALE
COMMUNIKATION

NR



SUMMER

Revestimiento de vegetación estabilizada con cobertura total 100% de plantas con base de hiedra e inserción de otras plantas preservadas (helechos, eucaliptos, salal, pittosporum).

Soporte en pvc flexible apto para superficies planas y curvas.
Escenografía equivalente a jardines vivos.

Stabilized vegetation lining with 100% total coverage of ivy-based plants and insertion of other preserved plants (ferns, eucalyptus, salal, pittosporum).

Flexible PVC support suitable for flat and curved surfaces.
Scenery equivalent to living gardens.





AUTUMN

Revestimiento de vegetación estabilizada con cobertura total 100% de plantas con base de hiedra e inserción de otras plantas preservadas (helechos, eucaliptos, salal, pittosporum).

Soporte en pvc flexible apto para superficies planas y curvas.
Escenografía equivalente a jardines vivos.

Stabilized vegetation lining with 100% total coverage of ivy-based plants and insertion of other preserved plants (ferns, eucalyptus, salal, pittosporum).

Flexible PVC support suitable for flat and curved surfaces.
Scenery equivalent to living gardens.





LEAFAGE

Cobertura total 100% de hiedra preservada con soporte en pvc flexible apto para superficies curvas: Escenografía equivalente a jardines vivos.

Stabilized vegetation lining with full coverage 100% preserved ivy. Flexible PVC support suitable for flat and curved surfaces. Scenery equivalent to living gardens.



MILLENNIUM

Revestimiento **personalizado** de vegetación estabilizada con cobertura total con vegetación natural preservada.
Soporte en pvc flexible apto para superficies planas y curvas.

Customized coating of stabilized vegetation with total coverage with preserved natural vegetation.
Flexible PVC support suitable for flat and curved surfaces.

Para realizar la composición MILLENIUM totalmente personalizado:

1. Seleccionar los modelos dentro de la composición:



2. Enviar dibujo del diseño, indicar en cada parte el modelo a seleccionar y medidas (ancho y alto)

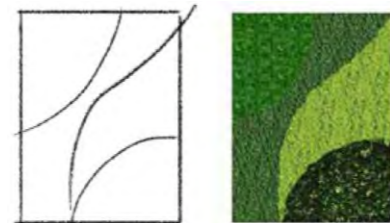

To create a fully customised MILLENIUM composition:

1. Select the models within the composition:

2. Send a drawing of the design, indicating in each part the model to be selected and sizes (width and height).





☆1

A1-14

PA



VENUS

Jardines colgantes de 18 o 23 cm. de diámetro con vegetación mixta natural preservada (asparagina, eucalipto stuartiana, espárragos)

Hanging gardens of 18 or 23 cm diameter with preserved natural mixed vegetation (asparagine, eucalyptus stuartiana, asparagus).

JARDINES COLGANTES



SKY

Jardín colgante con estructuras redondas de hierro esmaltados color antracita con dimensiones diferentes y posibilidad de colgar a 3 alturas, con frondosa vegetación natural preservada variada de amarantos, helecho espárrago, hiedra mini, eucalipto cinérea, eucalipto populus, eucalipto Nicolý y eucalipto Tiki. Posibilidad de personalizar la vegetación bajo requerimiento.

Alturas de las plantas: aprox. 50 cm.

Hanging gardens with round structures in anthracite enameled steel with different dimensions and the possibility of hanging at 3 heights.

Lush preserved natural vegetation varied from amaranths, asparagus fern, mini ivy, eucalyptus cinerea, eucalyptus populus, eucalyptus Nicolý and eucalyptus Tiki.

Possibility of customizing the vegetation upon request.

Plant heights: approx. 50cm

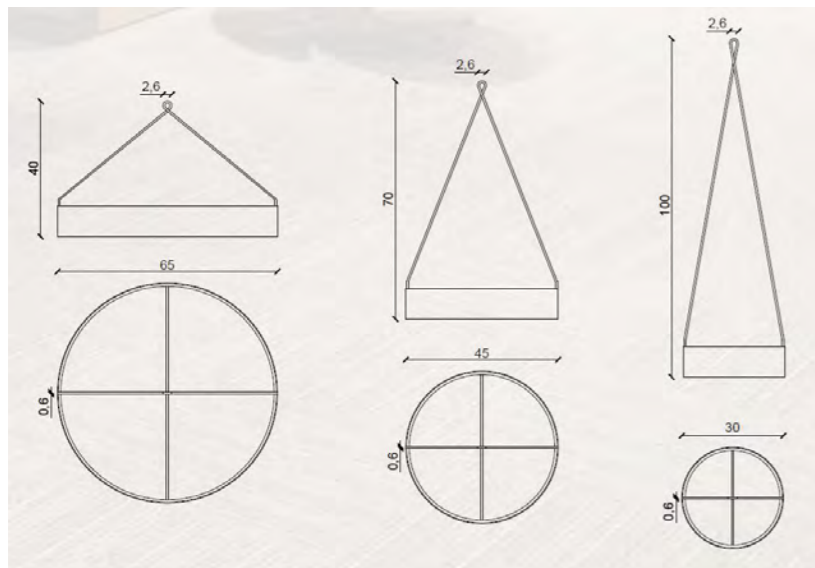

XELU ACOUSTIC

Revestimiento de vegetación estabilizada MOSS con cobertura total 100% en 12 colores. Colores de serie: Grass –Forest. Para otros colores: bajo presupuesto.

Esta versión ha sido diseñada concretamente para una prestación fonoabsorbente más eficaz. La vegetación preservada se fija sobre una base de corcho natural (material natural fonoabsorbente).

Espesor total: 5 cm (soporte en corcho: natural 3 cm + vegetación 2 cm.)

MOSS stabilized vegetation coating with 100% total coverage in 12 colours. Standard colours: Grass –Forest. For other colours: low budget.

This version has been specifically designed for a more effective sound absorbing performance. The preserved vegetation is fixed on a base of natural cork (natural sound-absorbing material).

Total thickness: 5 cm (natural cork support 3 cm + vegetation 2 cm.)



ACOUSTIC GRAPHIC

Hz	125	250	500	1000	2000	4000
Benetti Moss	0,08	0,14	0,28	0,42	0,39	0,34
Sughero - Licheni	0,38	0,48	0,53	0,66	0,61	0,67

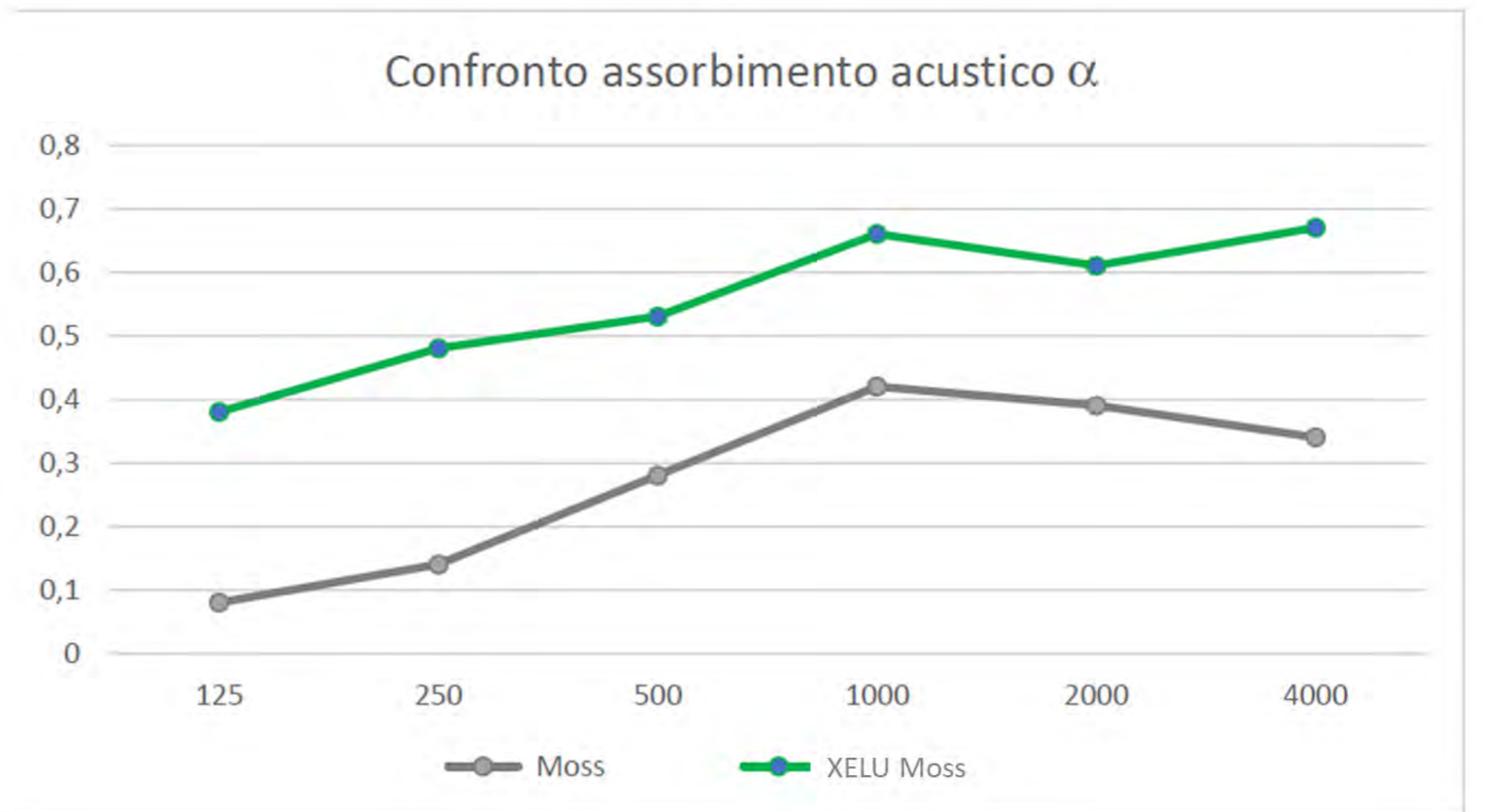

Como está científicamente comprobado, el ruido afecta a la salud de las personas y, si el ruido es excesivo, produce estrés, enfermedades cardiovasculares y cansancio.

Según la Organización Mundial de la Salud (OMS), el excesivo ruido es la segunda causa de enfermedades graves (solo por detrás de la contaminación ambiental).

Por lo tanto, si bien todas nuestras versiones de jardines verticales tienen propiedades fonoabsorbentes, hemos decidido profundizar en el tema y crear una versión aún más eficaz para disminuir el ruido ambiental: la versión XELU ACOUSTIC.

La base donde se fija la vegetación preservada Moss es de corcho natural.
Un material fonoabsorbente en sí mismo.

Por lo tanto, las ondas sonoras penetran en la superficie porosa del corcho (espesor 3 cm.) y en su mayor parte no rebota hacia el exterior (reverberación).
Paralelamente, también el espesor de la vegetación MOSS aplicada sobre la base de corcho obstaculiza aún más la reverberación del ruido.

XELU ACOUSTIC es una propuesta acústica 100% natural: corcho + vegetación preservada.

As is scientifically proven, noise affects people's health and, if noise is excessive, it causes stress, cardiovascular diseases and fatigue.

According to the World Health Organization (WHO), excessive noise is the second cause of serious illnesses (only behind environmental pollution).

Therefore, although all our versions of vertical gardens have sound-absorbing properties, we have decided to go deeper into the subject and create an even more effective version to reduce ambient noise: the XELU ACOUSTIC version.

The base where the Moss preserved vegetation is fixed is made of natural cork.
A sound absorbing material in itself.

Therefore, the sound waves penetrate the porous surface of the cork (thickness 3 cm) and for the most part do not bounce towards the outside (reverberation).
In parallel way, also the thickness of the MOSS vegetation applied on the cork base further hinders the reverberation of noise.

XELU ACOUSTIC is a 100% natural acoustic proposal: cork + preserved vegetation.

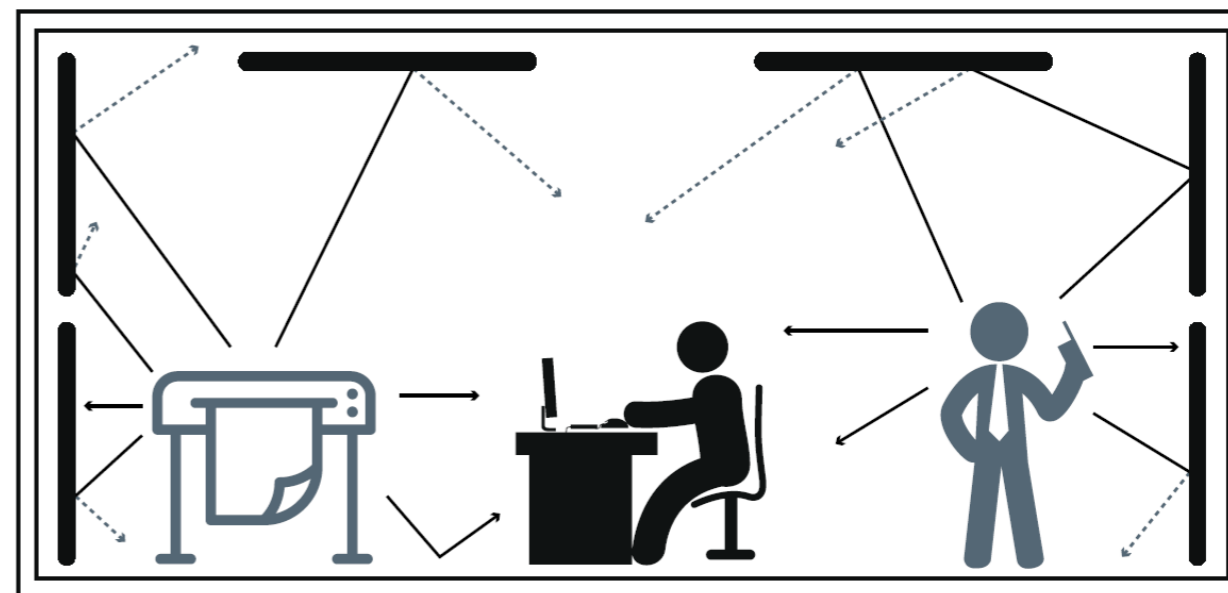
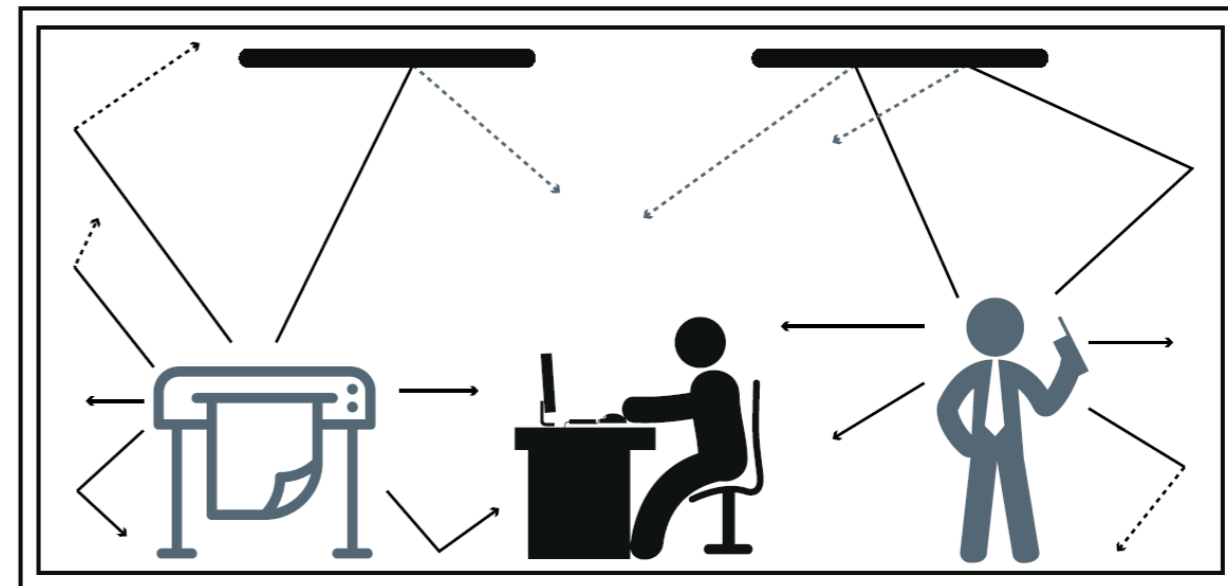
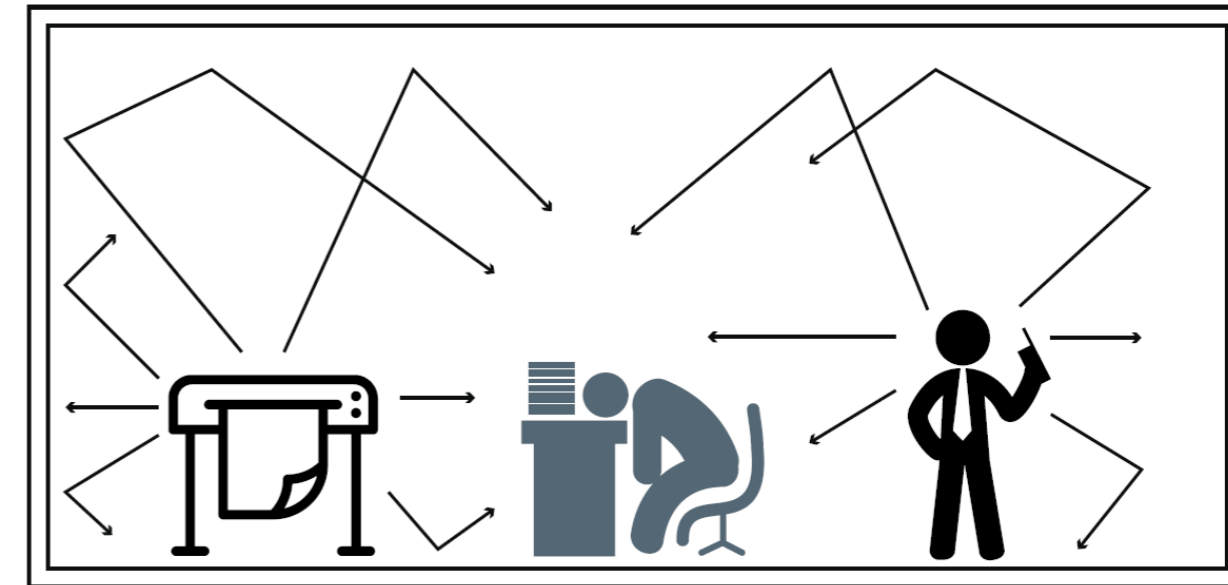



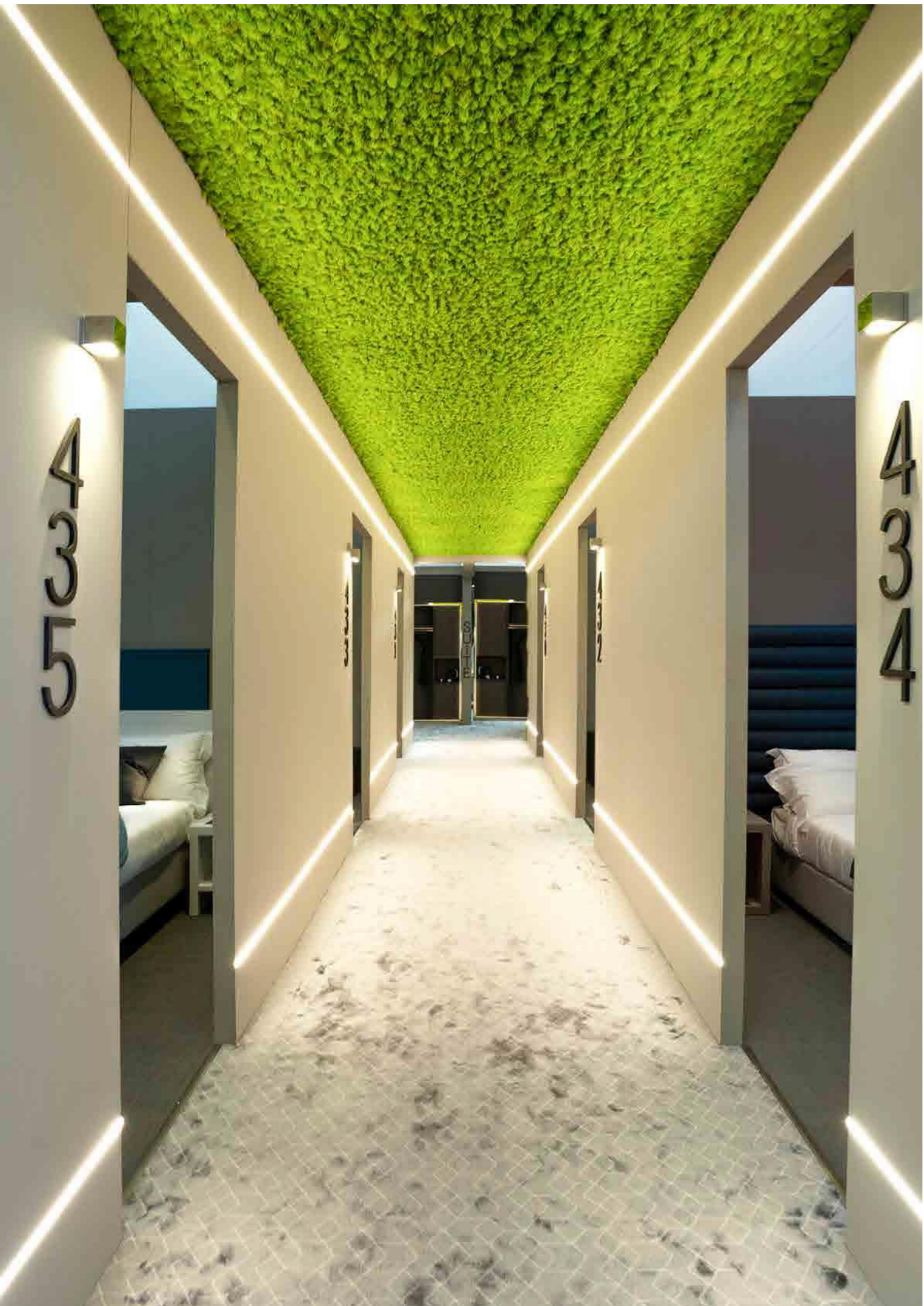

XELU acoustic a techo



XELU acoustic a pared





XELU pared

IDEAS PLANTS





IDEAS PLANTS

Ampliamos la posibilidad de incorporar naturaleza en los interiores con nuestra propuesta de plantas preservadas que no requieren mantenimiento.

De esta manera, complementando los revestimientos de paredes y techos o posicionándolas en zonas interiores abiertas, aportamos verde para el bienestar de las personas.

Suministramos solo la vegetación preservada o también con nuestros maceteros con diseños diferentes (incluso con iluminación interior).

Para entradas de edificios, lobby de hoteles, salas de espera, separando espacios en restaurantes u oficinas y tantas otras zonas interiores, son soluciones biofílicas que destacarán los ambientes de forma notoria.

Proponemos diferentes composiciones de plantas preservadas a medida, adaptándonos a cada proyecto, para seleccionar aquellas que mejor se adapten a cada espacio interior.

We expand the possibility of incorporating nature into interiors with our proposal of preserved plants that do not require maintenance.

In this way, complementing the wall and ceiling coverings or positioning them in open interior areas, we contribute green for people's well-being.

We supply only the preserved vegetation or also with our planters with different designs (even with interior lighting).

For building entrances, hotel lobbies, waiting rooms, separation of areas in restaurants or offices and many other interior areas, they are biophilic solutions that will highlight the environments in a noticeable way.

We propose different customized compositions of preserved plants, adapting to each project, to select those that best suit each interior space.







MY FLOWER

Jardinera de metal fijas o con ruedas para facilitar su desplazamiento.

Metal planter fix or with wheels for easy movement.

L120 x P30 x H120 cm

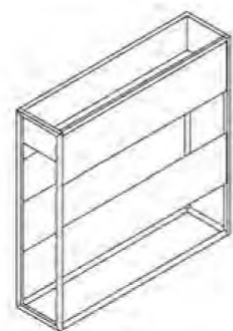

L120 x P30 x H97 cm





MINI FLOWER

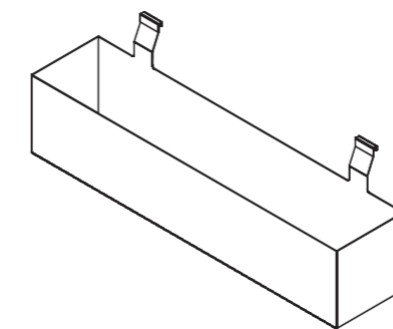



DUBAI

Macetero en polietileno en varios colores y diferentes medidas.

Opcional: iluminación (solo color neutro)

Polyethylene planter in various colours and sizes.

Optional: lighting (only neutral colour).

FLORES

Macetero con 3 huecos en polietileno color neutro.

Opcional: iluminación (4 puntos de luz)

Planter with 3 holes in neutral-coloured polyethylene. Optional: lighting (4 light points).

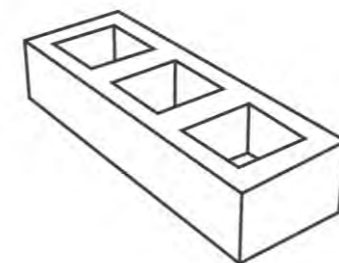

Dimensioni (cm.)

L. 148 - Li 30

H. 31 - Hi 23

P. 49 - Pi 30



70 - 90 - 129

Ø65

Ø85

Ø118 non illuminabile



FLORIDA

Macetero en polietileno en varios colores.

Opcional:

- Iluminación
- Soporte interno

Polyethylene planter in various colours.

Optional:

- Lighting
- Internal support

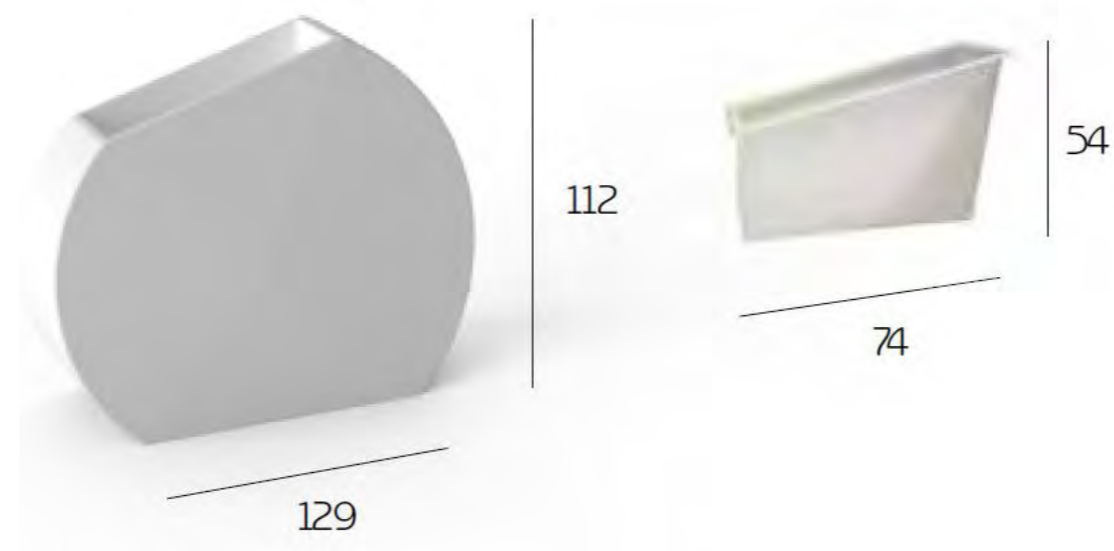



IVREA-VOGHERA

Macetero en polietileno en varios colores.
Opcional: iluminación (solo color neutro)

Polyethylene planter in various colours. Optional: lighting (neutral colour only).



NIAGARA-VICTORIA

Macetero en polietileno en varios colores.

Polyethylene planter in various colours.

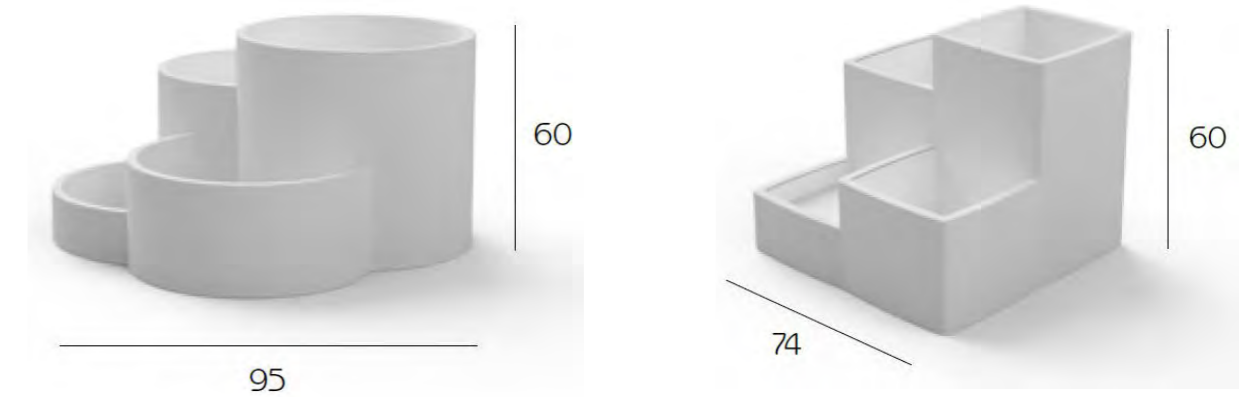
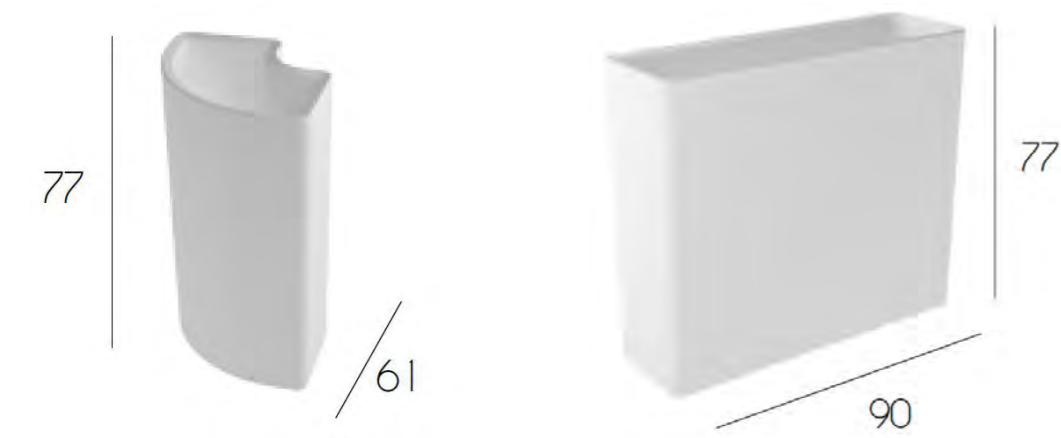



HONOLULU

Macetero en polietileno en varios colores.
Prof.59.

Opcional: iluminación (solo color neutro)

Polyethylene planter in various colours.
Prof.59.

Optional: lighting (only neutral colour).





I D E A S L O G O

IDEAS LOGO

Fabricación de identificaciones corporativas de empresas, comercios, asociaciones, etc ..., en cualquier medida y forma, con líquenes naturales preservados rellenando estructuras huecas de pvc de color blanco o negro.

El sistema de montaje permite distanciar ligeramente el logo de la pared creando un efecto de suspensión.

Manufacture of corporate identifications of companies, shops, associations, and so on..., in any size and shape, with preserved natural lichens filling hollow white or black PVC structures.

The mounting system allows the logo to be slightly distanced from the wall, creating a suspension effect.



1. Marcar en la pared según la plantilla que se envía.
2. Atornillar los soportes.
3. Detrás del logotipo habrá unas resinas para fijarlo dentro de los soportes colocados en la pared.

1. Mark on the wall according to the template provided.
2. Screw on the brackets.
3. Behind the logo there will be resins to fix it into the brackets on the wall.

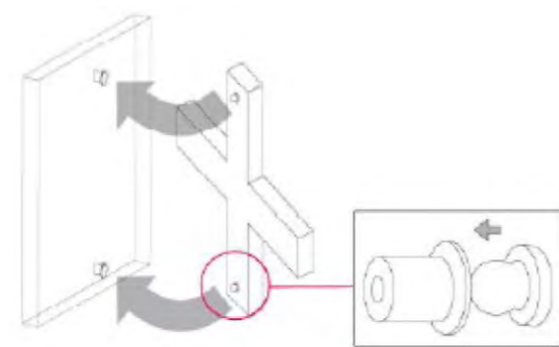







REALIZED PROJECTS

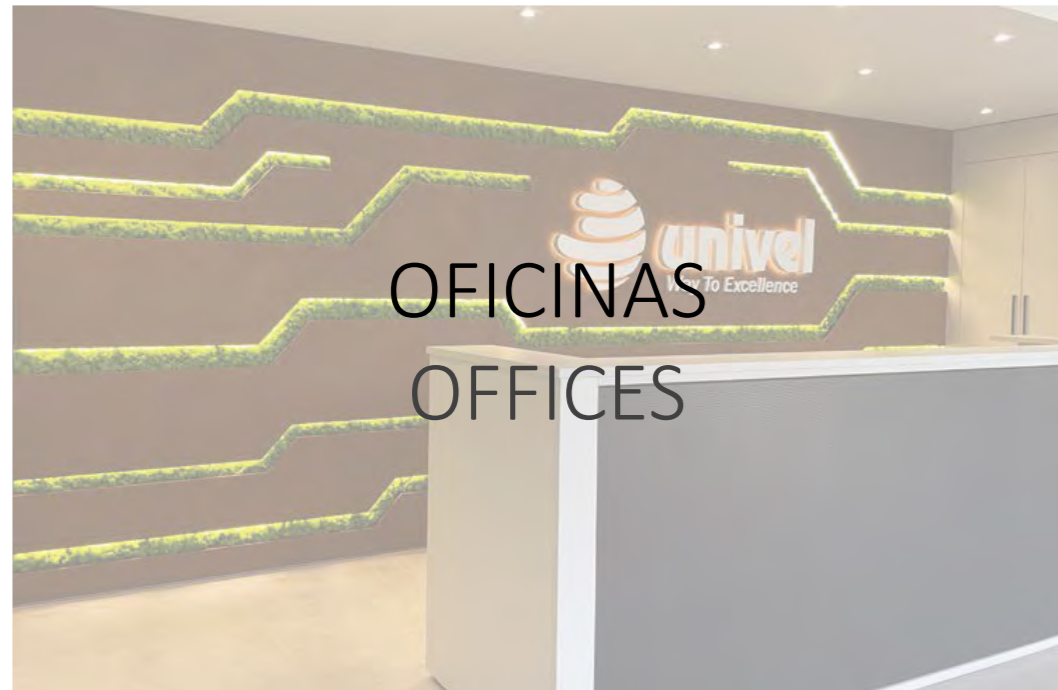

El bienestar psicofísico de los empleados está en el centro de los intereses de las empresas y quienes deciden invertir en la mejora de sus espacios comprenden su importancia estratégica.

Según Forbes, los espacios **biofílicos** son un avance necesario en el diseño del lugar de trabajo obteniendo una importante reducción de enfermedades y nivel de absentismo por parte de los trabajadores (Wageningen Environmental Research).

Un entorno menos estresante es más productivo y el uso de materiales éticos refuerza plenamente la sostenibilidad de la marca, posicionándola como respetuosa con el medio ambiente y la ecología.

Todos los espacios de oficina se rediseñan siguiendo un proyecto específico y dedicado, centrado en las necesidades del cliente, utilizando productos ecológicos prácticos y manejables, sin necesidad de mano de obra profesional y sin necesidad de mantenimiento.

Además, el aislamiento acústico hace que las estancias sean más confortables, absorbiendo el ruido de forma natural y mejorando la concentración de quienes trabajan en ellas.

The psychophysical well-being of employees is at the centre of companies' interests and those who decide to invest in improving their spaces understand its strategic importance.

According to Forbes, **biophilic** spaces are a necessary advance in workplace design, resulting in a significant reduction in illness and absenteeism levels among workers (Wageningen Environmental Research).

A less stressful environment is more productive and the use of ethical materials fully reinforces the sustainability of the brand, positioning it as environmentally and ecologically friendly.

All office spaces are redesigned following a specific and dedicated project, focused on the customer's needs, using practical and manageable eco-friendly products, with no need for professional labour and no maintenance. In addition, the acoustic insulation makes the rooms more comfortable, absorbing noise naturally and improving the concentration of those who work in them.



OFICINAS
OFFICES





amazon

The image shows a modern interior space with a wall of horizontal wood slats. On the left, the Amazon logo is mounted in silver. To the right, a large living wall of green plants is installed. In the foreground, a white reception counter is visible. The ceiling has recessed lighting.





ROQUETTE
Offering the best of nature™

Daily healthy nutrition
Environmentally friendly

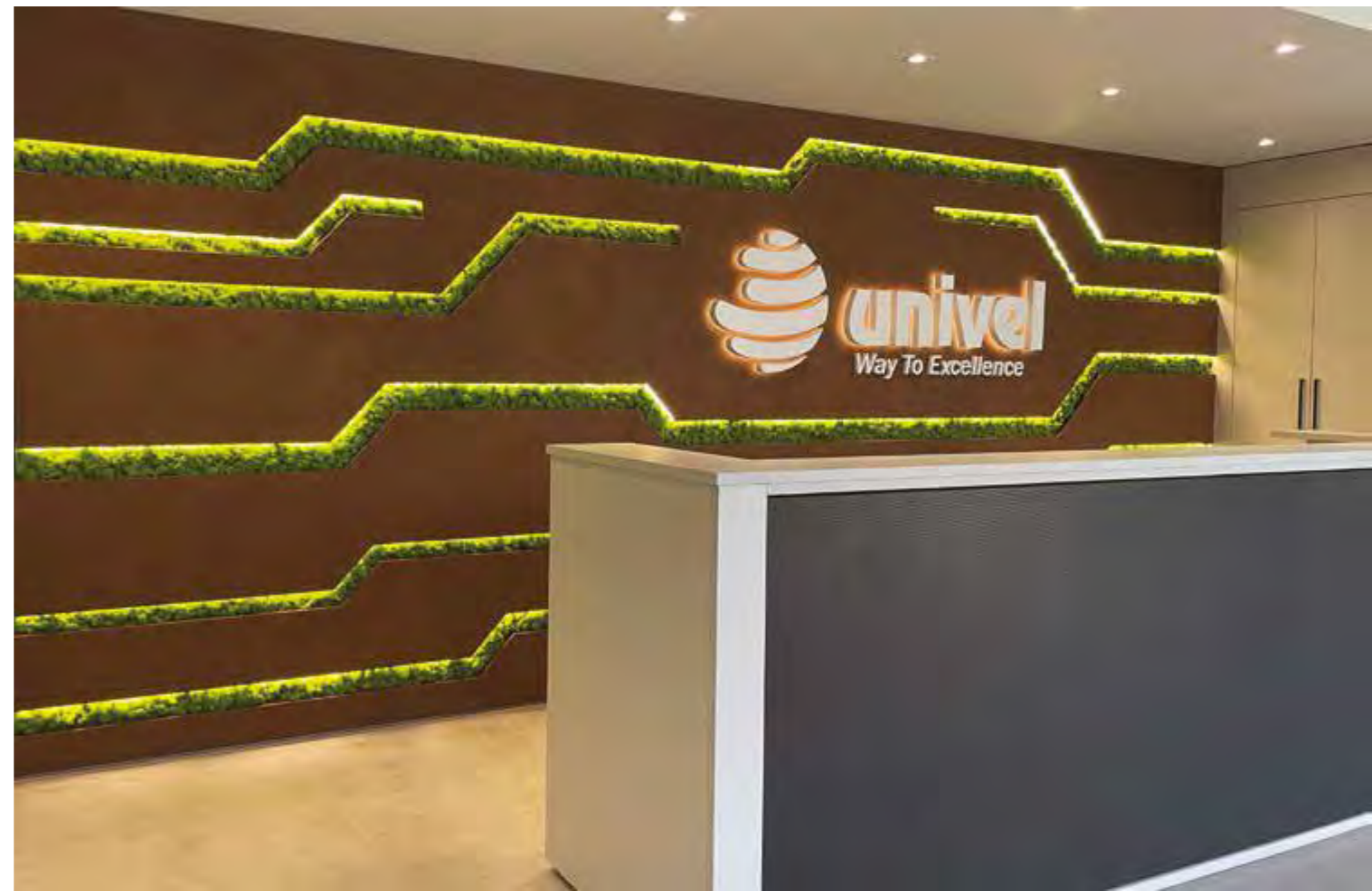



El sector de la restauración observa con atención y curiosidad las nuevas tendencias del mercado y opta por adoptar un diseño ético y sostenible, en consonancia con los beneficios de la **biofilia** y la sensación de armonía y confort que transmite.

Cada vez estamos más acostumbrados a compartir nuestros momentos especiales en redes sociales y esto ocurre especialmente en bares y restaurantes, donde una ubicación interesante y única es uno de los factores decisivos a la hora de elegir dónde comer, por lo que optar por un espacio relajante rodeado de naturaleza resulta un efecto psicológico crucial.

La fonoabsorbencia natural de nuestros productos favorece un ambiente relajado y agradable, protegido del ruido exterior, que se absorbe suavemente para garantizar una experiencia de despreocupación y no estresante.

Cada producto mural o de techo es fácil de montar y colocar en el lugar que se elija, no necesita la intervención de un profesional y no requiere mantenimiento a lo largo de los años.

La experiencia del cliente es primordial y el diseño de espacios funcionales y estéticamente agradables es esencial.

The restaurant sector is observing with attention and curiosity the new market trends and opting to adopt ethical and sustainable design, in line with the benefits of **biophilia** and the sense of harmony and comfort it conveys.

We are increasingly used to sharing our special moments on social media and this is especially true for bars and restaurants, where an interesting and unique location is one of the deciding factors when choosing where to eat, so opting for a relaxing space surrounded by nature is a crucial psychological effect

.The natural sound absorption of our products promotes a relaxed and pleasant atmosphere, protected from outside noise, which is gently absorbed to ensure a carefree and non-stressful experience. Each wall or ceiling product is easy to assemble and position in the location of your choice, requires no professional intervention and no maintenance over the years. Customer experience is paramount and the design of functional and aesthetically pleasing spaces is essential.

















Una nueva forma de viajar y experimentar el espacio que nos rodea es ahora un deseo compartido, al igual que la necesidad de un turismo sostenible y responsable.

El sector de la hostelería está asumiendo cada vez más estas cuestiones y pensando en el futuro, tomando decisiones ecológicas y respetuosas con el medio ambiente.

Quienes han depositado su confianza en nuestras propuestas **biofílicas**, obtienen un impacto visual evidente, ya que en las paredes o techos del vestíbulo, en el logotipo, cada lugar, atrae la mirada y llena los espacios de luz y verdor, compatibilizando con una clientela más atenta y sensible al medio ambiente y que busca y aprecia un estilo ético y refinado.

Las estructuras hoteleras aumentan su valor y se convierten en lugares de moda, únicos en su género, consiguiendo mejorar la experiencia de la estancia de cada cliente, combinando relajación y bienestar acústico, gracias a las paredes o techos fonoabsorbentes, capaces de amortiguar suavemente el ruido y aislar las tensiones y los ruidos procedentes del exterior y del caos de la vida cotidiana.

A new way of travelling and experiencing the space around us is now a shared desire, as is the need for sustainable and responsible tourism

.The hospitality sector is increasingly taking these issues on board and thinking about the future, making ecological and environmentally friendly choices.

Those who have placed their trust in our **biophilic** proposals, obtain a clear visual impact, since on the walls or ceilings of the lobby, on the logo, every place, attracts the eye and fills the spaces with light and greenery, making it compatible with a clientele that is more attentive and sensitive to the environment and that looks for and appreciates an ethical and refined style.

The hotel structures increase their value and become fashionable places, unique in their kind, managing to enhance the experience of each client's stay, combining relaxation and acoustic well-being, thanks to sound-absorbing walls or ceilings, capable of gently dampening noise and isolating stress and noise from the outside and from the chaos of everyday life.











En el comercio minorista, es crucial fomentar un ambiente relajado para mejorar la experiencia de compra del cliente, haciéndola única e incentivándole a ello.

De hecho, varios estudios registran que en los espacios comerciales que han adoptado un estilo ético y sostenible, con elementos **biofilicos**, las emociones positivas han elevado el valor percibido del producto y, por tanto, han aumentado los ingresos de la tienda en un alto porcentaje. La imagen de una marca es fundamental, al igual que el disfrute de sus espacios, y es necesario saber destacar y atraer la atención de los clientes potenciales. Hoy, de hecho, el 60% de los consumidores hacen una foto en los lugares que visitan o donde compran y luego la publican en las redes sociales. Todo ello favorece la reputación web y potencia la opción sostenible de diseñar el logotipo y los espacios propios con un enfoque ecológico y medioambiental. Nuestra vegetación preservada puede utilizarse como expositor, rodeando / enmarcando perfectamente los productos a la venta, y no requieren mantenimiento, son fáciles y rápidas de montar, sin necesidad de intervención de un profesional. Un ambiente relajado / **verde** crea un clima de compra saludable, sin estrés, con mayor disposición a permanecer en el sitio. Un clima de compra saludable resulta un punto fuerte de la tienda y el cliente se sentirá mimado y valorará la marca cercana y atenta a su salud.

In retail, it is crucial to foster a relaxed atmosphere to enhance the customer's shopping experience, making it unique and encouraging them to do so.

In fact, several studies record that in retail spaces that have adopted an ethical and sustainable style, with **biophilic** elements, positive emotions have increased the perceived value of the product and, therefore, have increased the shop's revenue by a high percentage. The image of a brand is fundamental, as is the enjoyment of its spaces, and it is necessary to know how to stand out and attract the attention of potential customers. Today, in fact, 60% of consumers take a photo of the places they visit or where they shop and then post it on social networks. All of this enhances web reputation and promotes the sustainable option of designing one's own logo and spaces with an ecological and environmental approach. Our preserved greenery can be used as a display, perfectly surrounding / framing the products for sale, and are maintenance free, easy and quick to assemble, without the need for professional intervention. A relaxed / green environment creates a healthy, stress-free shopping climate, with a greater willingness to stay on site. A healthy shopping climate is a strong point of the shop and the customer will feel pampered and will value the brand that is close and attentive to their health.

















SKY VALET
← SECURITY CONTROL
→ VIP LOUNGE
→ SKY VALET
→ BZAR
→ CREW LOUNGE
→ ♿

REALIZED PROJECTS

Restaurants

Co-working spaces

Clubs

Offices

Spa



Airports

Pubs

Retail

Gyms

Hotels

w w w . i d e a s g r o u p d e s i g n . c o m



IDEAS Group
c/ Pagsià, 26
08172 – Sant Cugat del Vallès
Barcelona (Spain)
Tel: (34) 93 027 42 54
contract@ideasgroup.es