

# Omelette

cinco

# Editions

**Omelette Editions**  
**volumen cinco**

**[www.omeletteeditions.com](http://www.omeletteeditions.com)**

**Cada detalle, gesto o textura que caracteriza los diseños de Omelette Editions busca crear una conexión emocional con quienes los observan y utilizan. Desde 2016, el objetivo de la editora es ofrecer colecciones de mobiliario que no solo perduren y obvien tendencias y modas, sino que se conviertan en eje vertebrador de los espacios y las vidas de quienes los habitan. En este sentido, Omelette Editions mantiene que el diseño trasciende ampliamente la mera apariencia. Los muebles, en su concepción, se entienden como entidades que van más allá de ser simples objetos; se integran y participan en una conversación simbiótica entre el diseño y la vida cotidiana.**

**Fundada por el estudio de diseño La Mamba como una plataforma para sus propias creaciones, Omelette Editions entiende el diseño como un diálogo entre diseñadores, industriales, arquitectos, interioristas y usuarios finales.**

**Esta perspectiva les permite desarrollar muebles funcionales y atemporales, garantizando así que cada pieza responda a las necesidades de aquellos que las incorporan en su día a día.**

**Como editora, busca colaborar con diseñadores cuya filosofía esté alineada con la de la marca, fomentando un diseño sencillo y honesto. Esto, sin embargo, no implica renunciar a la diversidad que caracteriza su catálogo, donde todas las piezas funcionan tanto individualmente como en conjunto. Estas colaboraciones enriquecen a la editora con múltiples perspectivas sobre el diseño, considerándolo un proceso que usa un lenguaje común.**

Every detail, gesture or texture that characterises Omelette Editions' designs seeks to create an emotional connection with those who observe and use them. Since 2016, the editor's goal has been to offer furniture collections that not only endure and obviate trends and fashions, but also become the backbone of spaces and the lives of those who inhabit them. In this sense, Omelette Editions believes that design goes far beyond mere appearance. Furniture, in its conception, is understood as entities that go beyond being mere objects; they are integrated and participate in a symbiotic conversation between design and everyday life.

Founded by design studio La Mamba as a platform for its own creations, Omelette Editions understands design as a dialogue between designers, industrialists, architects, interior designers and the user of the product. This perspective allows them to develop functional and timeless furniture, as well as ensuring that each piece responds to the needs of those who will incorporate it into their daily lives.

As a publisher, it seeks to collaborate with designers, whose philosophy is aligned with that of the brand, encouraging simple and honest design. This, however, does not imply renouncing the diversity that characterises its catalogue, where all the pieces work both individually and as a whole. These collaborations enrich the publisher with multiple perspectives on design, seeing it as a process that uses a common language.

# Diseñadorxs

# Designers



Altherr

Désile

Park

Ana

Motta



Francesc

Rifé

Isaac

Piñeiro

Omayra

Maymó



MUT

Design



La

Mamba





Savoye 8 Sofá Sofa



Majestic 16 Sofá Sofa



Must 24 Sofá Sofa



Masala 30 Sofá Sofa



Bolet 46 Butaca Lounge



Porta 52 Butaca Lounge



Alex 58 Butaca Lounge



Nua 62 Butaca Lounge



Savoye 68 Butaca Lounge



Majestic 72 Butaca Lounge

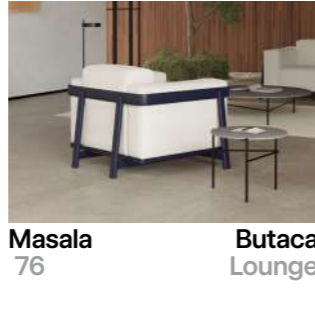

Masala 76 Butaca Lounge

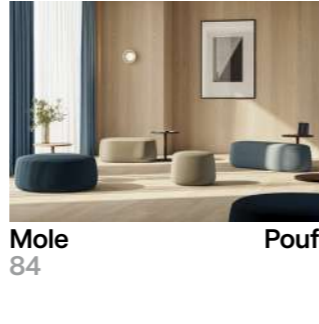

Mole 84 Pouf



Savoye 88 Pouf



Majestic 90 Pouf



Nua 94 Mesa Table



Domus 98 Mesa Table

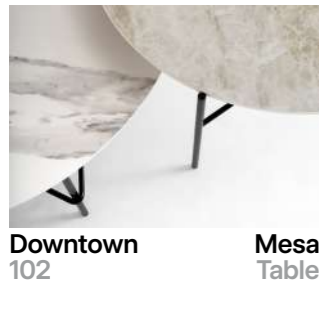

Downtown 102 Mesa Table



Bison 106 Mesa Table



Fold 108 Mesa Table



Ox 112 Mesa Table

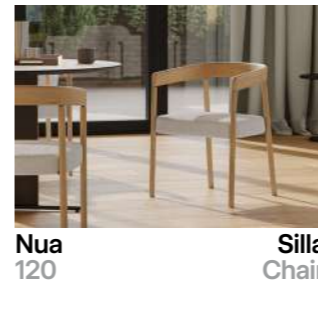

Nua 120 Silla Chair

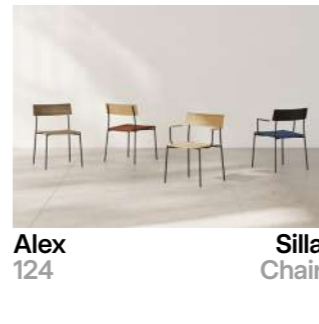

Alex 124 Silla Chair



Alex Bistro 130 Silla Chair



Terra Wood 134 Silla Chair



Terra Metal 138 Silla Chair

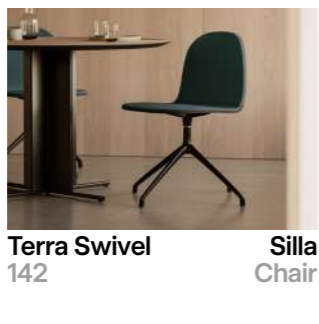

Terra Swivel 142 Silla Chair



Domus S65 152 Taburete Stool

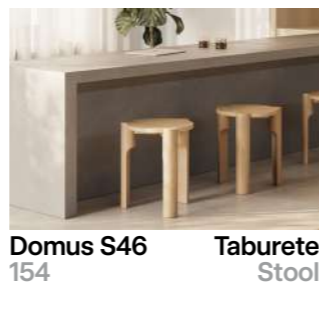

Domus S46 154 Taburete Stool



Terra 156 Taburete Stool



Alex Bistro 160 Taburete Stool



Sente 166 Accesorio Accesory



Vertical 170 Accesorio Accesory

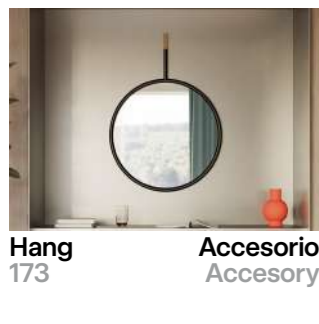

Hang 173 Accesorio Accesory



# Savoye



Designed by

# La Mamba

[ESP] El sofá Savoye está diseñado con bordes redondeados, su asiento mullido y respaldo crean una silueta relajada con asientos profundos que proporcionan un confort óptimo. Sus diferentes módulos ofrecen una variedad muy amplia de combinaciones entre ellos, permitiendo personalizar el sofá a nuestro gusto, convirtiéndolo en una opción versátil para diversos espacios ya sean residenciales o corporativos.

[ENG] The Savoye sofa is designed with rounded edges, its soft seat and backrest create a relaxed silhouette with deep seats that provide optimal comfort. Its different modules offer a wide variety of combinations between them, allowing you to customise the sofa to your liking, making it a versatile option for a variety of spaces whether residential or corporate.



↑ Composición modular sofá Savoye (113 + 090 + 113)  
Modular composition Savoye sofa (113 + 090 + 113)

← Composición modular sofá Savoye (113 + 090 + 090 + 113)  
Modular composition Savoye sofa (113 + 090 + 090 + 113)



← Composición modular sofá Savoye  
 OM SAVO COMP-06 (093 + 090 + 093)  
 Modular composition Savoye sofa  
 OM SAVO COMP-06 (093 + 090 + 093)

↗ Detalle módulo sofá Savoye OM SAVO 113  
 Detail Savoye sofa module OM SAVO 113

↙ Detalle módulo sofá Savoye OM SAVO 110  
 Detail Savoye sofa module OM SAVO 110

↘ Detalle módulo sofá Savoye OM SAVO 093  
 Detail Savoye sofa module OM SAVO 093







Composición modular sofá Savoye (090 + 090 + 090 + 090 + 110)  
Modular composition Savoye sofa (090 + 090 + 090 + 090 + 110)





↑ Composición modular sofá Savoye (113L con TAB + 090L + MP1)  
 Modular composition Savoye sofa (113L with TAB + 090L + MP1)

← Composición modular sofá Savoye  
 Frontal: MP1 + 090 + 090 + 113 + TAB  
 Trasera: 090 + 090 + 090 + 090  
 Modular composition Savoye sofa  
 Front: MP1 + 090 + 090 + 113 with TAB  
 Back: 090 + 090 + 090 + 090





[ESP] Majestic aúna comodidad y ligereza a partir de un sofá de líneas rectas y sinuosas que invita a disfrutar de un momento de intimidad, descanso o conversación amistosa, en un entorno que destila sofisticación y encanto. Estéticamente, una de sus características más distintivas es una base visible formada por un sistema de doble pata que revela la ligereza y la fuerza de la estructura.

[ENG] Majestic unites comfort and lightness based on a padded body that balances straight and sinuous lines, and invites you to enjoy a moment of intimacy, rest or a friendly conversation, in surroundings that ooze with sophistication and charm. Aesthetically, one of its most distinct features is a visible base made up of a double leg system that reveals the lightness and the strength of the structure.



↑ Sofá Majestic OM MAJE S4P  
Majestic Sofa OM MAJE S4P

← Sofá Majestic OM MAJE S4P  
Majestic Sofa OM MAJE S4P





↑ Detalle módulos sofá Majestic OM MAJE RI + OM MAJE MP1  
Detail Majestic sofa modules OM MAJE RI + OM MAJE MP1

→ Detalle módulo sofá Majestic OM MAJE MDB2  
Detail Majestic sofa module OM MAJE MDB2







Sofás Majestic OM MAJE S4PXL  
Majestic Sofas OM MAJE S4PXL





↑ **Composición modular sofá Majestic (CHL1 + MD2 + RI + MD2 + MP1)**  
 Modular composition Majestic sofa (CHL1 + MD2 + RI + MD2 + MP1)

← **Sofá Majestic OM MAJE S4PXL**  
 Majestic sofa OM MAJE S4PXL

# Must



Designed by

# La Mamba

[ESP] El Sofá Must consiste de dos elementos importantes: por una parte, una estructura tubular ovalada que da soporte y, por otro, una carcasa de madera tapizada que funciona como contenedor de la cojinería. Must nace del concepto bañera que almacena en su interior un conjunto de cojines que aportan gran confort y espacio para relajarse, apoyados en una estructura que igual que la silla Terra, centra toda su personalidad en la fortaleza de su estructura. De esta manera y a través de líneas suaves y atractivas, rompemos con las formas tradicionales del sofá y conseguimos crear una silueta diferente a lo que encontramos en el mercado.

[ENG] Must Sofa consists of two important elements: on the one hand, a tubular oval structure that forms the base, and then an upholstered, wooden framework that acts as a container for the cushions. Must has been created from the bath concept, accommodating a set of cushions that provide real comfort and space to relax, supported by a structure that, like the Terra chair, focuses all its personality in the strength of its structure. In this way and through its soft, attractive lines, we have broken away from the traditional lines of the sofa and have been able to create a different silhouette to that found on the market.



↑ Sofá Must OM MUST S4PXL  
Must sofa OM MUST S4PXL

← Sofá Must OM MUST S4P  
Must sofa OM MUST S4P





Sofás Must OM MUST S4P  
Must sofas OM MUST S4P





↑ **Sofá Must OM MUST S4PXL**  
Must sofa OM MUST S4PXL

← **Sofá Must OM MUST S4PXL**  
Must sofa OM MUST S4PXL





# Masala

Designed by

# La Mamba

[ESP] Una cuidada y visible estructura en madera de nogal americano o madera de haya, dota a la colección Masala de una gran personalidad. El asiento, respaldo y reposabrazos fabricados en espuma de poliuretano de diferentes densidades, cubiertos por un edredón de plumas de oca, ofrecen un gran confort. Un sofá riguroso y a la vez exquisito con tapizado desenfundable.

[ENG] An expressive, visible frame made of American walnut wood or beech wood, provides the Masala collection with great personality. The seat, backrest and armrests made of polyurethane foam with different densities, covered by a goose feather duvet, offer great comfort. A rigorous and at the same time exquisite sofa with removable upholstery.



↑ Sofá Masala OM MASA S4PXL  
con estructura en madera de nogal  
Masala SOFA OM MASA S4PXL  
with structure in walnut wood

← Sofá Masala OM MASA S4PXL con estructura  
en madera de haya lacada en rojo óxido  
Masala sofa OM MASA S4PXL with structure  
in beech wood lacquered in oxyde red





↑ Sofá Masala OM MASA S4PXL con estructura en madera de haya natural  
 Masala sofa OM MASA S4PXL with structure in natural beech wood

← Detalle sofá Masala OM MASA S4PXL con estructura en haya natural  
 Detail of Masala sofa OM MASA S4PXL with structure in natural beech wood





Sofás Masala OM MASA S4P con estructura en madera de haya lacada en rojo óxido  
Masala sofas OM MASA S4P with structure in beech wood lacquered in oxyde red



## SAVOYE MODULAR

Información técnica  
Technical information

## OM SAVO 093. \* Módulo lateral / Side module

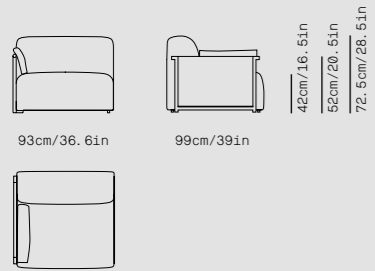

## OM SAVO 110. Módulo lateral / Side module

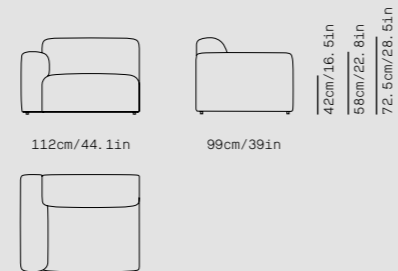

## OM SAVO 113. Módulo lateral / Side module

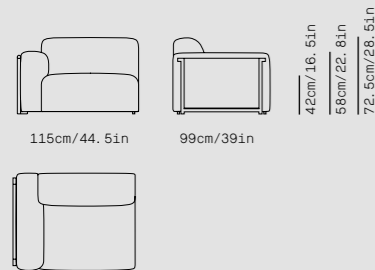

## OM SAVO 090. Módulo central / Central module

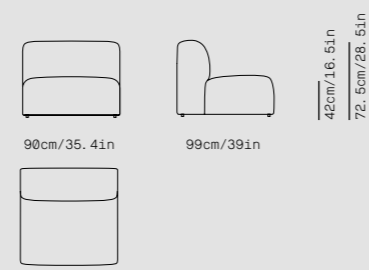

## OM SAVO RIN. Módulo rinconero / Corner module

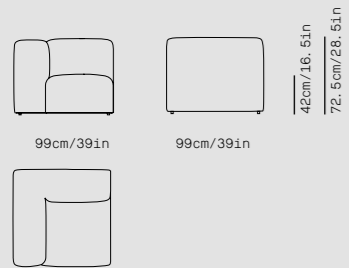

## OM SAVO MP1. Módulo pouf / Pouf module

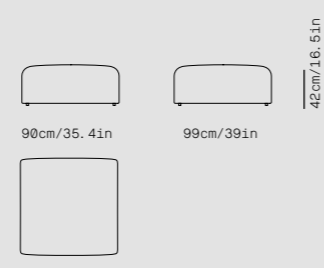

## OM SAVO P90. Pouf auxiliar / Auxiliar pouf

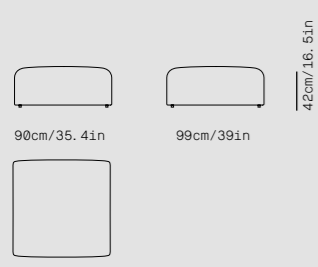

## SAVOYE MODULAR

Composiciones  
Compositions

## OM SAVO COMP-01. (110 + 110)

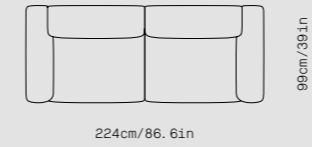

## OM SAVO COMP-02. (110 + 090 + 110)

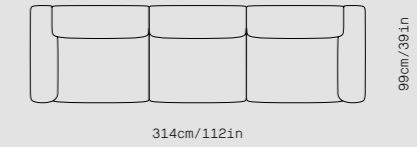

## OM SAVO COMP-03. (110 + 090 + MP1)

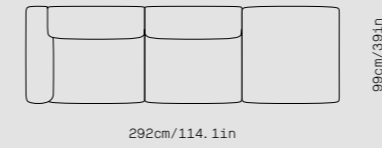

## OM SAVO COMP-04. (110 + 090 + MP1 + 110)

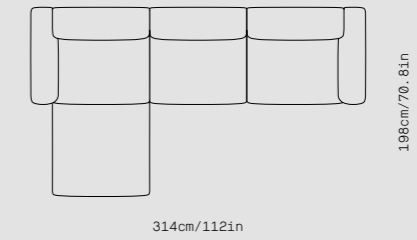

## OM SAVO COMP-05. \* (093 + 093)

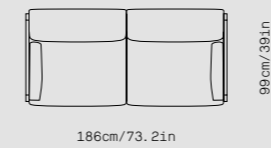

## OM SAVO COMP-06. \* (093 + 090 + 093)

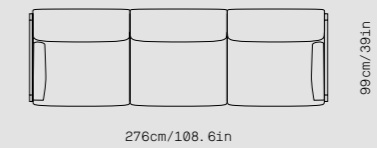

## OM SAVO COMP-07. \* (093 + 090 + MP1)

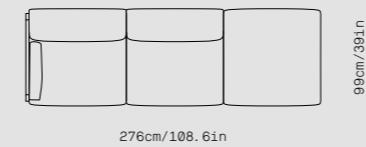

## OM SAVO COMP-08. \* (093 + 090 + MP1 + 093)

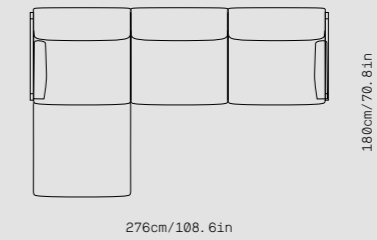

\* Los módulos con brazo metálico incluyen un cojín de 50 x 30 cm. / Modules with metal arm include a 50 x 30 cm cushion.

\* Las composiciones con brazo metálico incluyen un cojín de 50 x 30 cm por cada módulo lateral. / The compositions with metal arm include a 50 x 30 cm cushion for each side module.

## SAVOYE MODULAR L

Información técnica  
Technical information

## OM SAVO 093L. \* / \*\* Módulo lateral L / Side module L

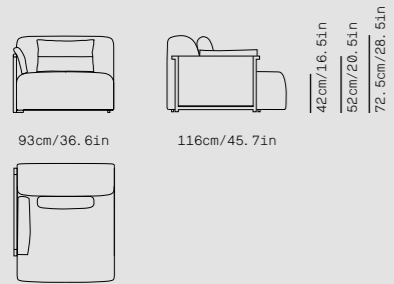

## OM SAVO 110L. \* Módulo lateral L / Side module L

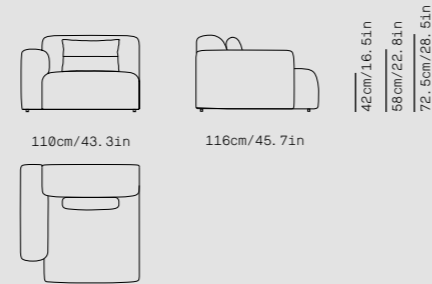

## OM SAVO 113L. \* Módulo lateral L / Side module L

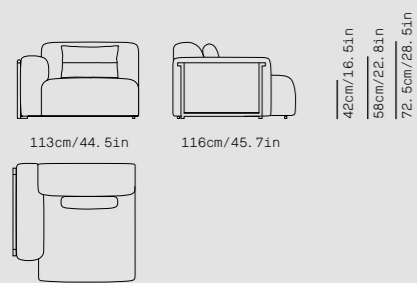

## OM SAVO 090L. \* Módulo central L / Central module L

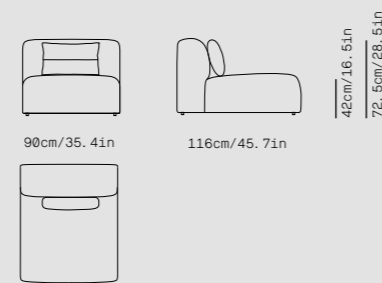

## OM SAVO RINL. \* Módulo rinconero L / Corner module L

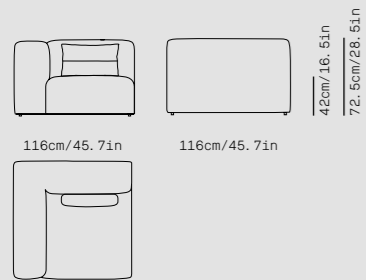

## SAVOYE MODULAR L

Composiciones  
Compositions

## OM SAVO L COMP-01. \* (110L + 110L)

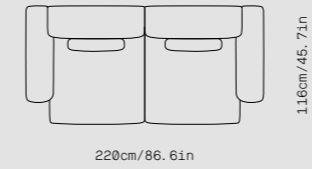

## OM SAVO L COMP-02. \* (110L + 090L + 110L)

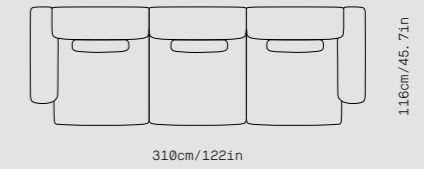

## OM SAVO L COMP-03. \* / \*\* (093L + 093L)

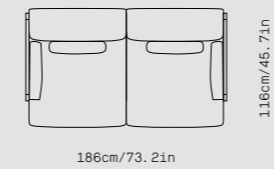

## OM SAVO L COMP-04. \* / \*\* (093L + 090L + 093L)

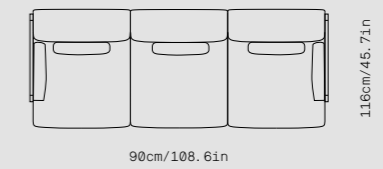

\* Los módulos L incluyen un cojín de 60 x 40 cm. / L modules include a 60 x 40 cm cushion.  
\*\* OM SAVO 093L incluye un cojín de 50 x 30 cm. / OM SAVO 093L includes a 50 x 30 cm cushion.

\* Las composiciones L incluyen un cojín de 60 x 40 cm por cada módulo. / L compositions include a 60 x 40 cm cushion for each module.  
\*\* Las composiciones con brazo metálico incluyen un cojín de 50 x 30 cm por cada módulo lateral. / The compositions with metal arm include a 50 x 30 cm cushion for each side module.

## SAVOYE

Complementos  
Complements

## OM SAVO 003. Lateral

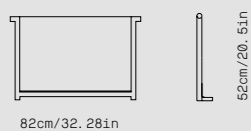

## OM SAVO TAB. Mesa auxiliar / Auxiliar table

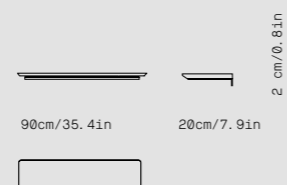

## OM SAVO C60. Cojín auxiliar / Auxiliar cushion



## OM SAVO C50. Cojín auxiliar / Auxiliar cushion



## MAJESTIC

Información técnica  
Technical information

## OM MAJE S2P. \* Sofá dos plazas / Two seater sofa

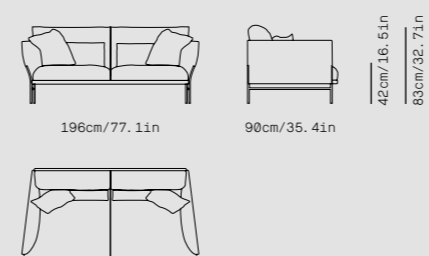

## OM MAJE S4P. \* Sofá cuatro plazas / Four seater sofa

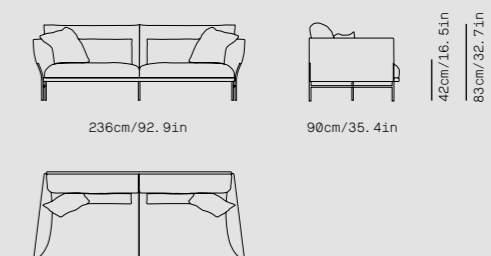

## OM MAJE S4PXL. \* Sofá cuatro plazas XL / Four seater sofa XL

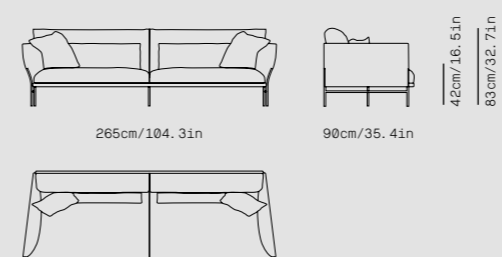

## OM MAJE CHLB2. \*\* Chaise longue

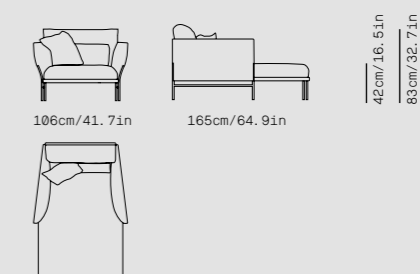

## OM MAJE PF90. Pouf auxiliar / Auxiliar pouf

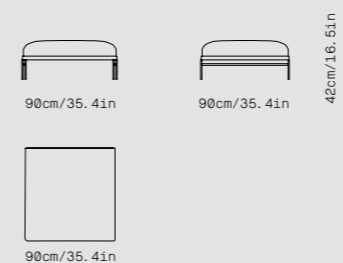

## OM MAJE C50. Cojín auxiliar / Auxiliar cushion

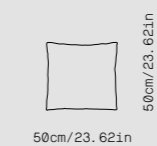

## OM MAJE C65. Cojín auxiliar / Auxiliar cushion



\* Los sofás Majestic incluyen dos cojines de 50 x 50 cm. / Majestic sofas include two 50 x 50 cm cushions.

\*\* OM MAJE CHLB2 incluye un cojín de 50 x 50 cm. / OM MAJE CHLB2 includes a cushion of 50 x 50 cm.



# MAJESTIC MODULAR

## Información técnica Technical information

### OM MAJE MDB1. \* Módulo lateral / Lateral module

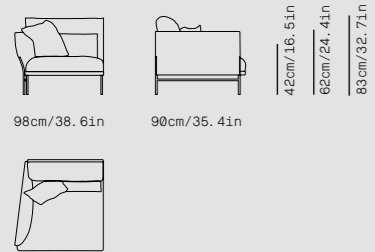

### OM MAJE MDB2. \* Módulo lateral / Lateral module

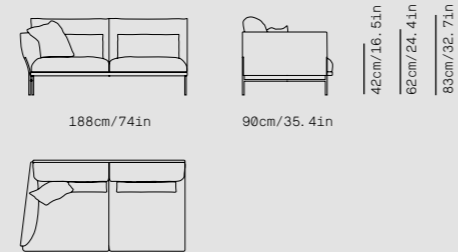

### OM MAJE MDB3. \* Módulo lateral / Lateral module

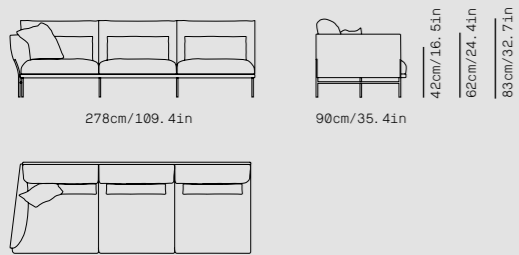

### OM MAJE MD2XL. \* Módulo lateral XL / Lateral module XL

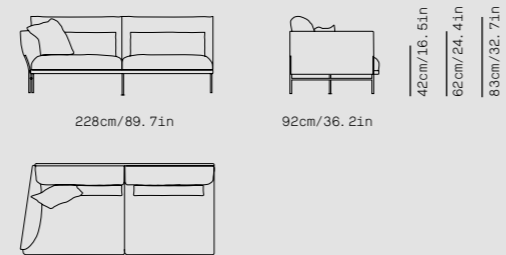

### OM MAJE MD1. Módulo central / Central module

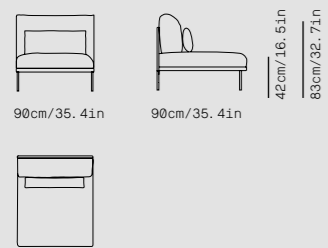

### OM MAJE MD2. Módulo central / Central module

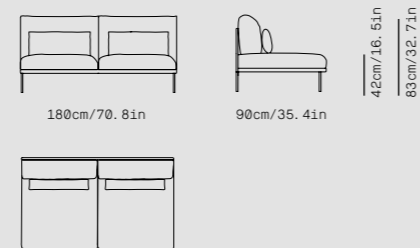

### OM MAJE MD3. Módulo central / Central module

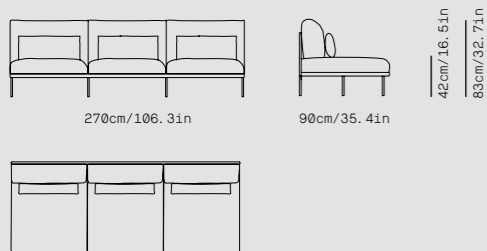

### OM MAJE MD2XL. Módulo central XL / Central module XL

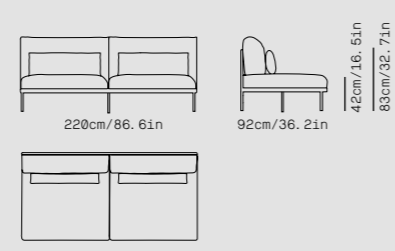

# MAJESTIC MODULAR

## Información técnica Technical information

### OM MAJE CHL1. \* Módulo chaise longue / Chaise longue module

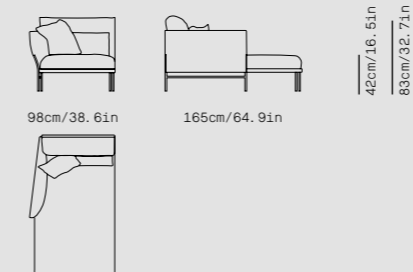

### OM MAJE RIN. \* Módulo rinconero / Corner module

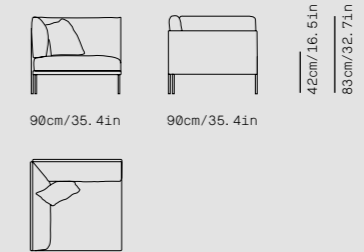

### OM MAJE MP1. Módulo pouf / Pouf module

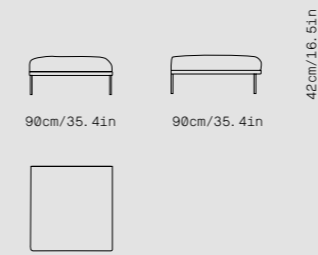

# MAJESTIC MODULAR

## Composiciones Compositions

### OM MAJE COMP-01. \*\* (MDB2 + CHL1)

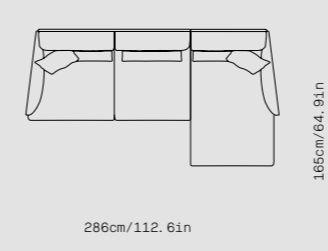

### OM MAJE COMP-01. \*\* (MDB2 + MRI + MD2 + MP1)

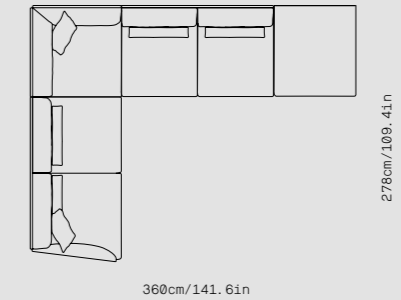

\* Los módulos laterales incluyen un cojín de 50 x 50 cm. / Lateral modules include a 50 x 50 cm cushion.

\* OM MAJE CHL1 y OM MAJE RIN incluyen un cojín de 50 x 50 cm. / OM MAJE CHL1 and OM MAJE RIN include a 50 x 50 cm cushion.  
\*\* Las composiciones incluyen dos cojines de 50 x 50 cm. / The compositions include two 50 x 50 cm cushions.

# MUST

## Información técnica Technical information

### OM MUST S4P. Sofá cuatro plazas / Four seater sofa

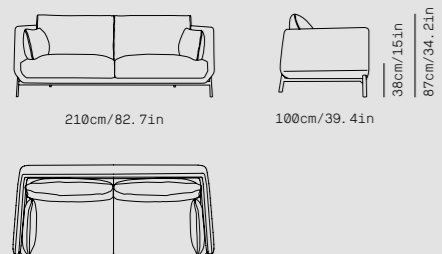

### OM MUST S4PXL. Sofá cuatro plazas XL / XL four seater sofa

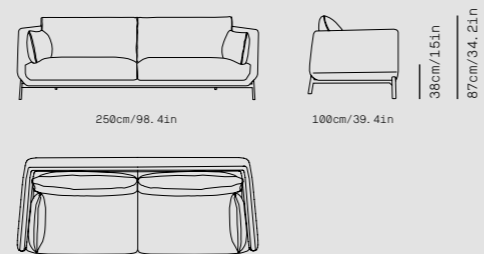

# MASALA

## Información técnica Technical information

### OM MASA S2P. Sofá dos plazas / Two seater sofa

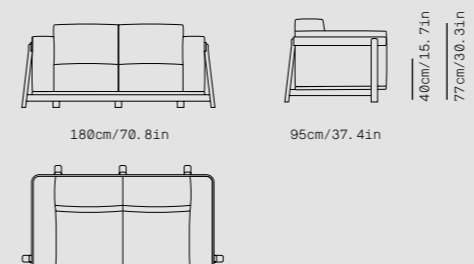

### OM MASA S3P. Sofá tres plazas / Three seater sofa

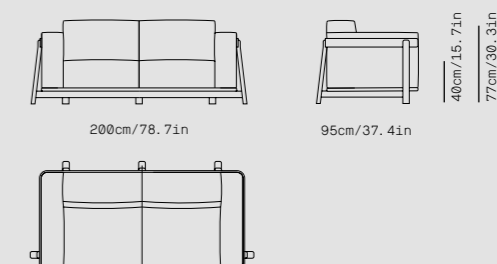

### OM MASA S4P. Sofá cuatro plazas / Four seater sofa

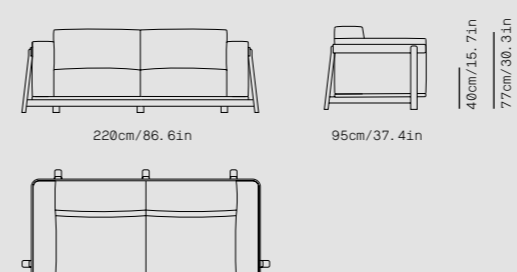

### OM MASA S4PXL. Sofá cuatro plazas XL / XL four seater sofa

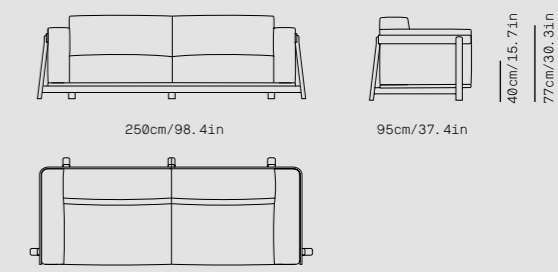

# Bolet



Designed by

# Mut

[ESP] Inspirada en el fascinante mundo de los hongos, Bolet evoca la forma de las setas. Es una butaca de tamaño ajustado que cabe en cualquier rincón. Su sencillez sólo se ve alterada por un toque elegante: el botón alargado en su centro, que caracteriza al diseño tanto funcional como estéticamente.

[ENG] Inspired by the fascinating world of mushrooms, Bolet evokes the shape of mushrooms. It is a small-sized seating collection that fits into any corner. Its simplicity is only altered by one elegant touch: the elongated button in its centre, which characterizes the design both functionally and aesthetically.



↑ Butaca Bolet OM BOLET en Grain 66232 y Grain 61256  
Bolet lounge OM BOLET in Grain 66232 and Grain 61256

← Butaca Bolet OM BOLET en Grain 62123  
Bolet lounge OM BOLET in Grain 62123



Butacas Bolet OM BOLET en Grain 61256  
Bolet lounges OM BOLET in Grain 61256





**Butacas Bolet OM BOLET en Grain 61250**  
 Bolet lounge OM BOLET in Grain 61250





# Porta



Designed by

# Omayra Maymó

[ESP] La butaca Porta surge de la observación del pórtico de entrada del Palacio de la Asamblea de Chandigarh, proyectado por Le Corbusier en 1951. La butaca es una abstracción del brutalismo y la dualidad de este pórtico, combinando el carácter suave y adaptable de un elemento protagonista curvo con el carácter riguroso y rectilíneo de los planos paralelos que lo soportan. Porta es una butaca de respaldo alto de gran confort. Su construcción rigurosa exhibe unos detalles sutiles y pulidos.

[ENG] The Porta armchair arose from observation of the entrance portico of the Chandigarh Assembly Hall, designed by Le Corbusier in 1951. The armchair is an abstraction of the brutalism and duality of this portico, combining the soft, adaptable character of a curved main element with the rigorous, rectilinear character of the parallel planes that support it. Porta is a high-backed armchair of great comfort. Its rigorous construction exhibits subtle, polished details.



↑ Butaca Porta OM PORTA V2 en Grain 66232  
Porta lounge OM PORTA V2 in Grain 66232

← Butaca Porta OM PORTA V2 en Grain 61251  
Porta lounge OM PORTA V2 in Grain 61251





Butacas Porta OM PORTA V1 en Grain 61250  
y OM PORTA V2 en Grain 62123  
Porta lounges OM PORTA V1 in Grain 61250  
and OM PORTA V2 in Grain 62123





← Butaca Porta OM PORTA V1 en Grain 61256  
 Porta lounge OM PORTA V1 in Grain 61256

↓ Butacas Porta OM PORTA V2 en Grain 61251  
 Porta lounge OM PORTA V2 in Grain 61251





# Alex



Designed by

# Isaac Piñeiro

[ESP] La idea de buscar una butaca de simplicidad extrema con elementos estándar y alcanzar un grado de expresividad suficiente para dotarla de identidad fue el comienzo de este proyecto. Se trata de una butaca informal que tiene una variedad de propósitos que van desde colocarla en áreas de recepción o espacios abiertos de una oficina a restaurantes u hogares. El nombre viene de Alexander Calder, punto de inspiración por sus esculturas y el punto de equilibrio que conseguía a través de las formas, las líneas el color y los diferentes materiales.

[ENG] The idea of looking for an extremely simple armchair with standard elements and achieving a sufficient degree of expressiveness to give it an identity was the beginning of this project. It is an informal armchair that has a variety of purposes ranging from being placed in reception areas or open spaces in an office to restaurants or homes. The name comes from Alexander Calder, a point of inspiration for his sculptures and the point of balance he achieved through shapes, lines, colour and different materials.



↑ Butaca Alex OM ALEX BVT1 con estructura en roble negro  
Alex lounge OM ALEX BVT1 with black oak structure

← Butaca Alex OM ALEX BVT1 con estructura en roble natural  
Alex lounge OM ALEX BVT1 with natural oak structure



↶ Butaca Alex OM ALEX BV1 con estructura en roble natural  
Alex lounge OM ALEX BV1 with natural oak structure

← Butaca Alex OM ALEX BV1 con estructura en roble negro  
Alex lounge OM ALEX BV1 with black oak structure

→ Butaca Alex OM ALEX BVT1 con estructura en roble natural  
Alex lounge OM ALEX BVT1 with natural oak structure





# Nua



Designed by

# Altherr Désile Park

[ESP] Nua es una butaca con una curvatura fluida en su respaldo y armoniosa en su simplicidad. Un asiento que, como el resto de los elementos de la marca, ha sido desarrollado con el objetivo de crear ambientes de interior perfectos, tanto en espacios residenciales como en contract, ya que se puede utilizar en diferentes rincones del hogar, pero también en salas de espera de un hotel, el hall de un restaurante, despacho o hospital. Nua lleva el concepto de confort, descanso, relajación, disfrute y de momentos de compartir del hogar al mundo hospitality, de la oficina y el retail y traspasa esa frontera más rígida propia de estos ámbitos.

[ENG] Nua is an armchair with a fluid curvature in its backrest and harmonious in its simplicity. A seat that, like the rest of the brand's elements, has been developed with the aim of creating perfect indoor environments, both in residential and contract spaces, as it can be used in different corners of the home, but also in hotel waiting rooms, the hall of a restaurant, office or hospital. Nua takes the concept of comfort, rest, relaxation, enjoyment and moments of sharing from the home to the world of hospitality, office and retail and goes beyond the more rigid boundaries of these areas.



↑ Butaca Nua OM NUA V1 con patas y respaldo en fresno negro y con cojín respaldo OM NUA RSP  
Nua lounge OM NUA V1 with legs and backrest in black ash and back cushion OM NUA RSP

← Butaca Nua OM NUA V1 con patas y respaldo en fresno negro  
Nua lounge OM NUA V1 with legs and backrest in black ash





↑ Butaca Nua OM NUA V1 con patas y respaldo en madera de fresno negro  
Nua lounge OM NUA V1 with legs and backrest in black ash wood

→ Butaca Nua OM NUA V1 con patas y respaldo en madera de fresno lacado azul oscuro  
Nua lounge OM NUA V1 with legs and backrest in dark blue lacquered ash







↑ Butacas Nua OM NUA V1 con patas y respaldo en roble natural, fresno humo y fresno negro  
Nua lounge OM NUA V1 with legs and backrest in natural oak, smoke ash and black ash.

← Butacas Nua OM NUA V1 con patas y respaldo en fresno lacado rojo óxido y fresno lacado azul oscuro  
Nua lounge OM NUA V1 with legs and backrest in oxyde red lacquered ash and dark blue lacquered ash.

# Savoye

[ESP] La butaca Savoye está diseñada con bordes redondeados, su asiento mullido y respaldo crean una silueta relajada que proporcionan un confort óptimo. Ofrece tres versiones: opción sin brazos, una segunda opción con brazos metálicos forrados en tejido y por último, la versión con brazos tapizados, ideal para espacios residenciales o corporativos.

[ENG] Savoye lounge is designed with rounded edges, its soft seat and backrest create a relaxed silhouette that provides optimal comfort. It offers three versions: an armless option, a second option with fabric covered metal arms and a third option with upholstered arms, ideal for residential or corporate spaces.



Designed by

# La Mamba



↑ Butaca Savoye OM SAVO 096  
Savoye lounge OM SAVO 096

← Butacas Savoye OM SAVO 090 y OM SAVO 096  
Savoye lounges OM SAVO 090 and OM SAVO 096





↑ Butaca Savoye OM SAVO 130  
Savoye lounge OM SAVO 130

← Butaca Savoye OM SAVO 090  
Savoye lounge OM SAVO 090



# Majestic



Designed by

# La Mamba

[ESP] Majestic aúna comodidad y ligereza a partir de un sofá de líneas rectas y sinuosas que invita a disfrutar de un momento de intimidad, descanso o conversación amistosa, en un entorno que destila sofisticación y encanto. Estéticamente, una de sus características más distintivas es una base visible formada por un sistema de doble pata que revela la ligereza y la fuerza de la estructura.

[ENG] Majestic unites comfort and lightness based on a padded body that balances straight and sinuous lines, and invites you to enjoy a moment of intimacy, rest or a friendly conversation, in surroundings that ooze with sophistication and charm. Aesthetically, one of its most distinct features is a visible base made up of a double leg system that reveals the lightness and the strength of the structure.



Butacas Majestic OM MAJE B2  
Majestic lounges OM MAJE B2



→ Butaca Majestic OM MAJE CHLB2  
Majestic lounge OM MAJE CHLB2

↓ Butaca Majestic OM MAJE B2  
Majestic lounge OM MAJE B2



# Masala

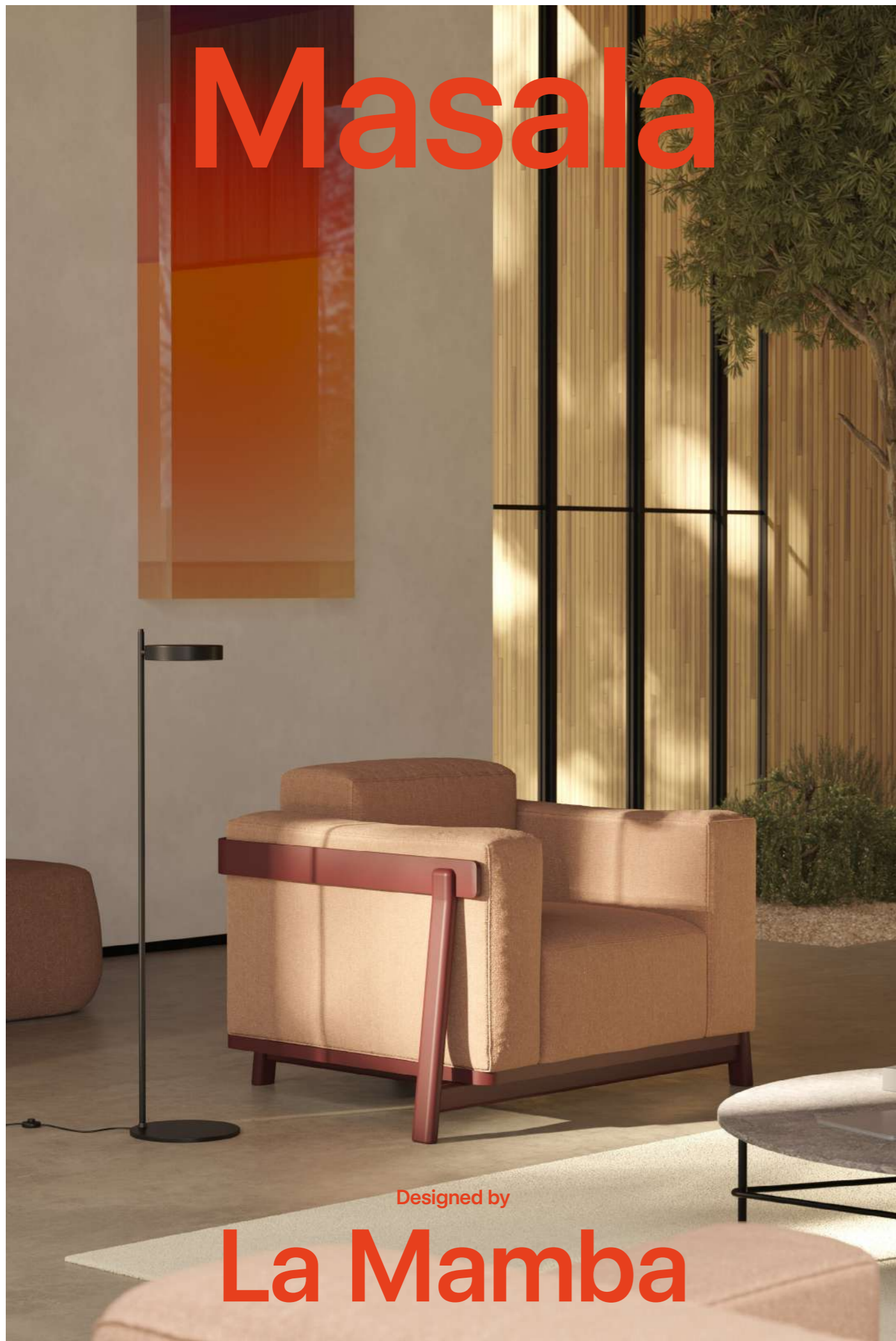

Designed by

# La Mamba

[ESP] Una cuidada y visible estructura en madera de nogal americano o madera de haya, dota a la colección Masala de una gran personalidad. El asiento, respaldo y reposabrazos fabricados en espuma de poliuretano de diferentes densidades, cubiertos por un edredón de plumas de oca, ofrecen un gran confort. Una butaca rigurosa y a la vez exquisita con tapizado desenfundable.

[ENG] An expressive, visible frame made of American walnut wood or beech wood, provides the Masala collection with great personality. The seat, backrest and armrests made of polyurethane foam with different densities, covered by a goose feather duvet, offer great comfort. A rigorous and at the same time exquisite lounge with removable upholstery.



↑ Butaca Masala OM MASA B2 con estructura en madera de haya lacado azul oscuro  
Masala lounge OM MASA B2 with structure in dark blue lacquered beech wood

← Butaca Masala OM MASA B2 con estructura en madera de haya lacado rojo óxido  
Masala lounge OM MASA B2 with structure in oxyde red lacquered beech.



↓ Butaca Masala OM MASA B2 con estructura en madera de haya lacado azul oscuro  
 Masala lounge OM MASA B2 with structure in dark blue lacquered beech

→ Butacas Masala OM MASA B2 con estructura en madera de haya lacado negro  
 Masala lounges OM MASA B2 with structure in black beech

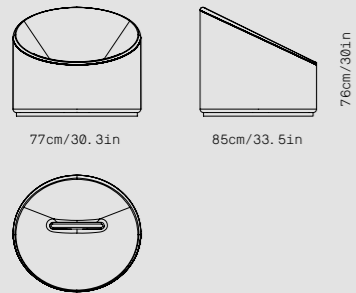
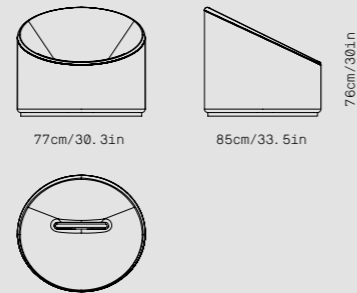
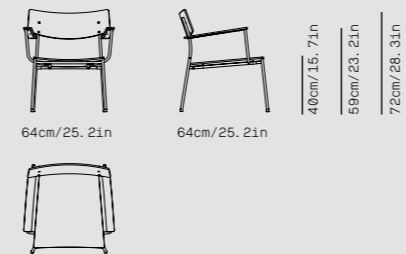
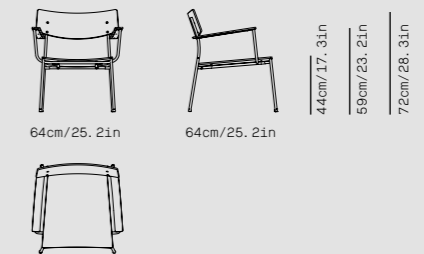
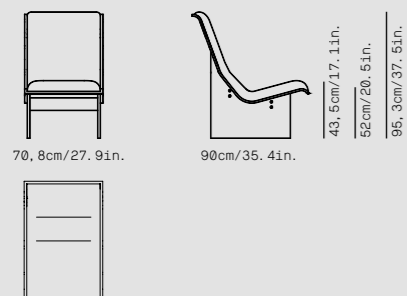
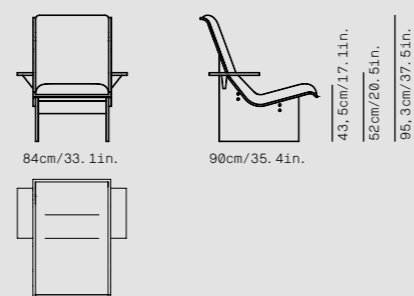
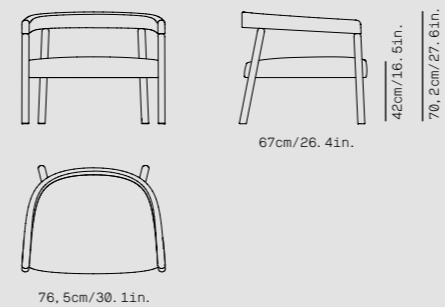
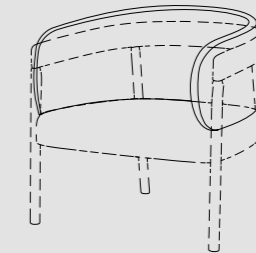

**BOLET****Información técnica**  
Technical information**OM BOLET FX. Butaca fija / Fixed lounge****OM BOLET SW. Butaca giratoria con retorno / Swivel lounge with return****ALEX****Información técnica**  
Technical information**OM ALEX BV1. Sin tapizar / Unupholstered****OM ALEX BVT1. Tapizada / Upholstered****PORTA****Información técnica**  
Technical information**OM PORTA VT1. Sin reposabrazos / Without armrests****OM PORTA VT2. Con reposabrazos / With armrests****NUA****Información técnica**  
Technical information**OM NUA V1. Asiento tapizado / Upholstered seat****OM NUA RSP. Cojín de respaldo / Back cushion**



## SAVOYE

Información técnica  
Technical information

## OM SAVO 090. Butaca / Lounge

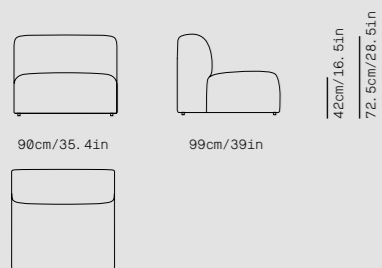

## OM SAVO 113. Butaca / Lounge

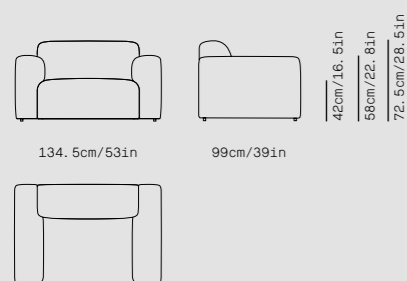

## OM SAVO 096. Butaca / Lounge

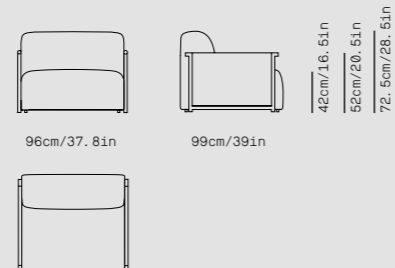

## MAJESTIC

Información técnica  
Technical information

## OM MAJE B2. Butaca / Lounge

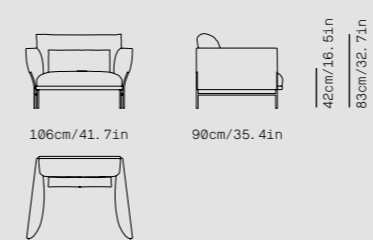

## OM MAJE CHLB2. \* Chaise Longue

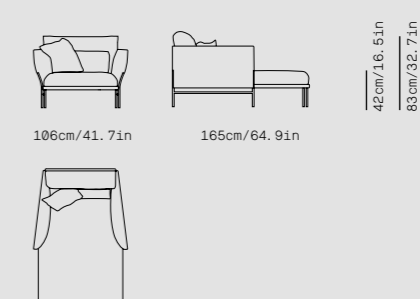

\* OM MAJE CHLB2 incluye un cojín de 50 x 50 cm. / OM MAJE CHLB2 includes a cushion of 50 x 50 cm.

## MASALA

Información técnica  
Technical information

## OM MASA B2. Butaca / Lounge

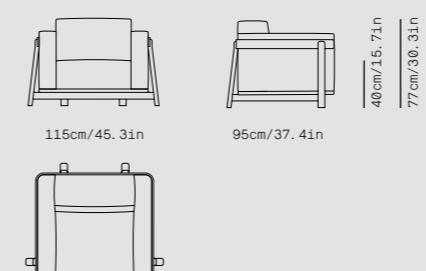



[ESP] Las formas orgánicas y geométricas definen esta versátil colección de poufs que aportan carácter y personalidad a los espacios públicos y privados.

[ENG] Organic and geometrical shapes define this versatile collection of poufs that provide public and private spaces with character and personality.

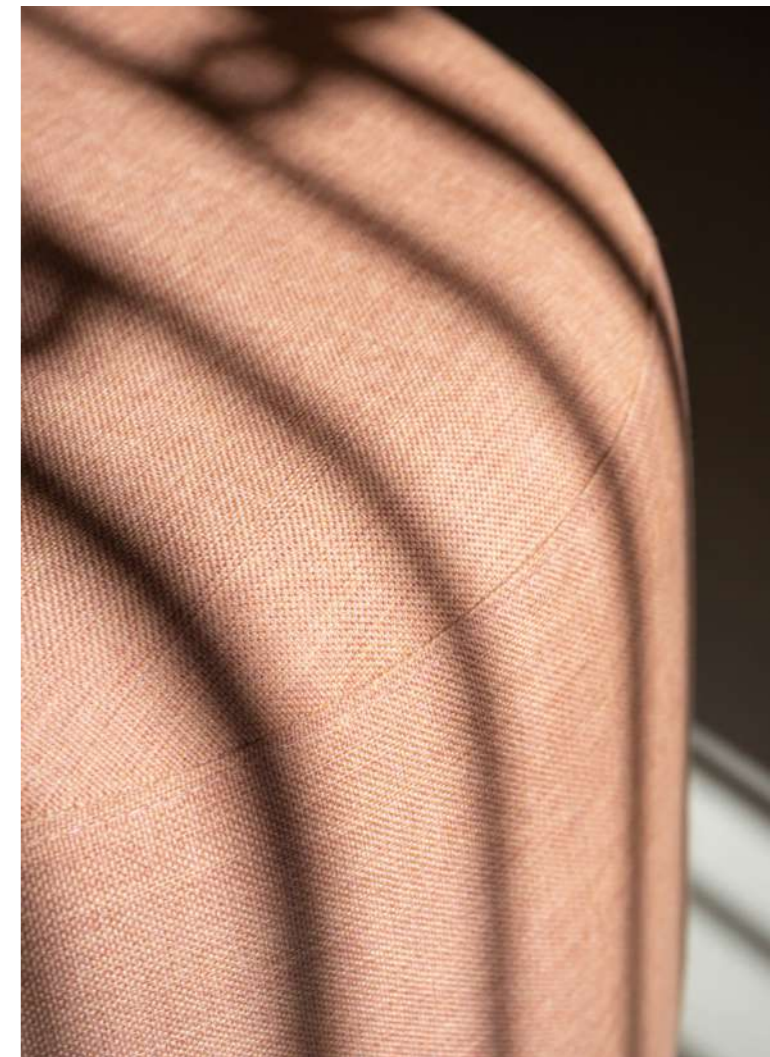

↑ Pouf Mole OM MOLE D58  
Mole Pouf OM MOLE D58  
← Pouf Mole OM MOLE D100  
Mole Pouf OM MOLE D100





Composición de poufs Mole OM MOLE D100, OM MOLE OV100, OM MOLE D58 y OM MOLE OV150  
Composition of Mole poufs OM MOLE D100, OM MOLE OV100, OM MOLE D58 and OM MOLE OV150





# Savoye

Designed by

# La Mamba

[ESP] De la colección de butacas y sofás Savoye, el pouf es la continuación de módulo con bordes redondeados y asiento mullido que proporciona un confort óptimo. Su modularidad nos permite crear diferentes composiciones y utilizarlo como pouf independiente, continuación de asiento, convertirlo en una chaise longue o en bancadas con pouf continuos.

[ENG] From the Savoye collection of lounges and sofas, the pouf is the continuation of a module with rounded edges and a soft seat that provides optimal comfort. Its modularity allows us to create different compositions and use it as an independent pouf, as a continuation of a seat, as a chaise longue or as a bench with a continuous pouf.



↑ Composición poufs Savoye OM SAVO P90  
Composition Savoye poufs OM SAVO P90

← Pouf Savoye OM SAVO P90  
Savoye pouf OM SAVO P90





# Majestic

Designed by

# La Mamba

[ESP] El pouf Majestic es uno de los asientos más versátiles de la colección, con sus líneas rectas y sinuosas sin perder la comodidad y la ligereza que lo caracteriza, es un asiento que nos permite crear bancadas continuas, pouf independiente o la continuación de asientos con bordes redondeados y asiento mullido proporcionando un confort óptimo. Su modularidad nos permite hacer diferentes composiciones, como bancadas o como modulo independiente para colocar frente al sofá a manera de reposapiés.

[ENG] The Majestic pouf is one of the most versatile seats of the collection, with its straight and sinuous lines without losing the comfort and lightness that characterizes it, it is a seat that allows us to create continuous benches, independent pouf or the continuation of seats with rounded edges and soft seat providing optimum comfort. Its modularity allows us to make different compositions, as benches or as an independent module to place in front of the sofa as a footrest.



Pouf Majestic OM MAJE PF90  
Majestic pouf OM MAJE PF90

# MOLE

## Información técnica Technical information

### OM MOLE D58. Pouf

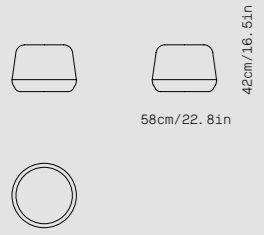

### OM MOLE OV100. Pouf

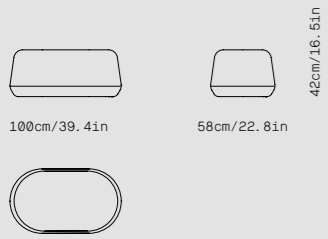

### OM MOLE D100. Pouf

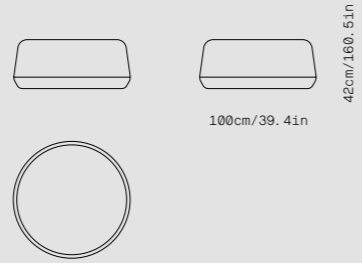

### OM MOLE OV150. Pouf

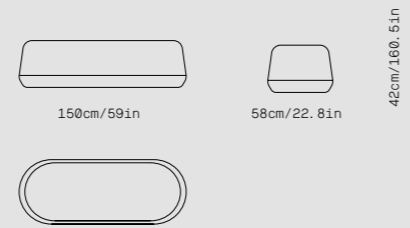

# SAVOYE

## Información técnica Technical information

### OM SAVO P90. Pouf

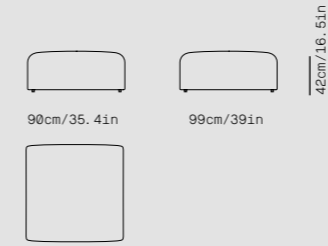

# MAJESTIC

## Información técnica Technical information

### OM MAJE PF90. Pouf

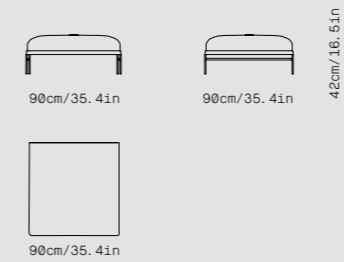



# Nua



Designed by

# Altherr Désile Park

[ESP] Continuando con la colección Nua, nace la mesa auxiliar replicando detalles como los radios en el mástil creando una sensación de ligereza en los encuentros. Es una mesa versátil para poder acompañar cualquiera de nuestros sofás o butacas. Disponible en diferentes acabados como el resto de la colección.

[ENG] Continuing with the Nua collection, the side table is born replicating details such as the spokes in the mast creating a sense of lightness in the meetings. It is a versatile table to accompany any of our sofas or armchairs. Available in different finishes like the rest of the collection.



↑ Mesa auxiliar Nua OM NUA en roble natura  
Nua side table OM NUA in natural oak wood

← Mesa auxiliar Nua OM NUA en fresno lacado rojo óxido  
Nua side table OM NUA in oxyde red lacquered ash wood





Composición de mesas auxiliares Nua OM NUA con base y sobre en fresno lacado azul oscuro, fresno lacado rojo óxido y fresno negro  
 Nua side table OM NUA composition with base and top in dark blue lacquered ash, rust red lacquered ash and black ash



# Domus



Designed by

# Isaac Piñeiro

[ESP] La colección Domus parte de una afirmación "Es una colección que me encantaría producirla yo mismo en un taller de madera por su sencillez y forma robusta" Isaac Piñeiro, diseñador. Un ejercicio de simplicidad, sobriedad y carácter, con dos detalles que lo definen, del corte de la pata y su encuentro con la parte del sobre. La colección de mesas auxiliares y de centro se completa con unos taburetes de dos altura.

[ENG] The Domus collection is based on a statement; "It is a collection that I would love to produce myself in a carpenter's workshop, owing to its simplicity and robust form" Isaac Piñeiro, designer. An exercise in simplicity, sobriety and character, defined by two details, the cut of the leg and its meeting with the top. The collection of occasional and centre tables is complemented with stools in two heights.



↑ Composición de mesas auxiliares Domus OM DOMUS 045 y OM DOMUS 100 en roble macizo natural  
Composition of Domus side tables OM DOMUS 045 and OM DOMUS 100 in natural solid oak

← Composición de mesas auxiliares Domus OM DOMUS 045 y OM DOMUS 120 en roble macizo natural  
Composition of Domus side tables OM DOMUS 045 and OM DOMUS 120 in natural solid oak





↑ Mesa auxiliar Domus OM DOMUS 120 en roble macizo natural  
Domus side table OM DOMUS 120 in solid natural oak

→ Composición de mesas auxiliares Domus OM DOMUS 071  
y OM DOMUS 100 en roble macizo natural  
Composition of Domus side tables OM DOMUS 071  
and OM DOMUS 100 in natural solid oak







[ESP] La colección de mesas Downtown es una sinfonía de líneas simples y formas básicas que se contraponen en alturas y tamaños, para crear, como si de un collage se tratara, un juego de volúmenes en el espacio. Un conjunto de mesas auxiliares de centro cuyos detalles definen su diseño, con una línea dinámica que envuelve su estructura.

[ENG] The collection of Downtown tables is a symphony of simple lines and basic shapes that offset each other in height and size, to create a set of volumes in space, as if it were a collage. A group of side and coffee tables whose details define their design, with a dynamic line that surrounds their structure.



↑ Composición de mesas auxiliares Downtown OM DOWN D120 con tablero en Grafite Dekton Mate y Kelya Dekton Mate y OM DOWN D85 con tablero en madera de nogal  
Composition of Downtown side tables OM DOWN D120 with top in Grafite Dekton Matte and Kelya Dekton Matte and OM DOWN D85 with top in walnut wood

← Composición de mesas auxiliares Downtown OM DOWN 5050 con tablero en madera de roble natural y OM DOWN 5040 con tablero en Opera Dekton Mate  
Composition of side tables Downtown OM DOWN 5050 with top in natural oak wood and OM DOWN 5040 with top in Opera Dekton Matt



↓ Mesa auxiliar Downtown OM DOWN D85 con tablero en madera de roble negro  
Downtown side table OM DOWN D85 with black oak wood top

→ Composición de mesas auxiliares Downtown OM DOWN 120 con tablero en madera de roble natural, OM DOWN 85 en madera de roble negro y OM DOWN 5050 en Grafite Dekton Mate  
Composition of side tables Downtown OM DOWN 120 with top in natural oak wood, OM DOWN 85 in black oak wood and OM DOWN 5050 in Grafite Dekton Matt





# Bison



Designed by

La Mamba

[ESP] Bison es una colección de mesas auxiliares disponibles en dos tamaños con un alto dinamismo visual gracias a la posibilidad de combinar acabados, rompiendo la monotonía de los espacios. Ideal para entornos residenciales y colectividades. La colección de mesas bajas auxiliares Bison destacan por su trazado simple y único, que conferirá a cualquier espacio la superficie ideal para dejar nuestros objetos favoritos o nuestra taza de café. La mesas cuentan con una estructura de tres patas y un sobre de aspecto fino y delgado.

[ENG] Bison is a collection of side tables available in two sizes. Visually dynamic thanks to the possibility of combining finishes, it breaks with the monotony of the spaces. They are ideal for residential and contract environments. Bison side tables stand out for their simple, unique outline, which will lend any space the ideal surface to leave our favourite objects or coffee cup. The tables have a three-legged structure and a slim, elegant table top.



↑ Composición mesas auxiliares Bison OM BISON 045 con estructura en madera de fresno macizo humo, fresno macizo negro y fresno macizo natural  
Composition side tables Bison OM BISON 045 with solid smoke ash, solid black ash and solid natural ash wood structure

← Composición mesas auxiliares Bison OM BISON 045 con estructura en madera de fresno macizo humo y OM BISON 071 en fresno macizo negro  
Composition side tables Bison OM BISON 045 with structure in solid smoke ash wood and OM BISON 071 in solid black ash



# Fold



Designed by

# La Mamba

[ESP] Diseñada como una opción de almacenamiento versátil, la mesa Fold está abierta a diversas interpretaciones, una mesa auxiliar independiente o una mesa para acompañar al sofá Savoye. Encarnando la pureza en su grado más elegante, la estricta geometría de esta mesa nos recuerda a los principios estéticos de la Bauhaus.

[ENG] Designed as a versatile storage option, the Fold table is open to a variety of interpretations, a freestanding side table or a table to accompany the Savoye sofa. Embodying purity at its most elegant, the strict geometry of this table is reminiscent of Bauhaus aesthetic principles.

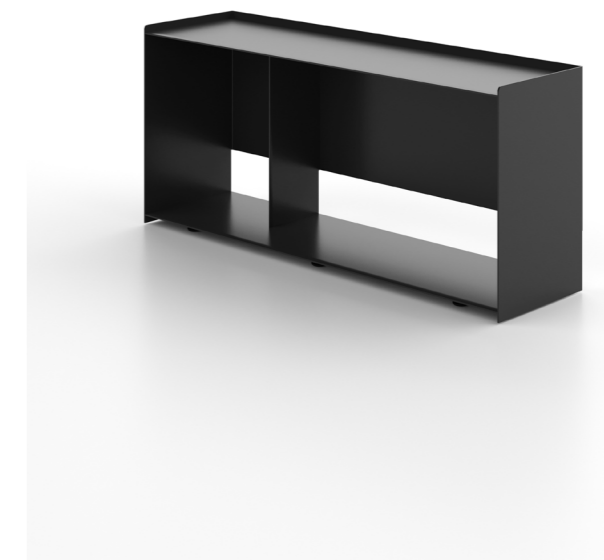

Mesa auxiliar Fold OM FOLD con estructura en negro  
Fold side table OM FOLD with black structure.





↑ Mesa auxiliar Fold OM FOLD con estructura en rojo flúor  
 Fold side table OM FOLD with fluorescent red structure

→ Mesa auxiliar Fold OM FOLD con estructura en blanco  
 Fold side table OM FOLD with white structure







[ESP] Como si se tratara de un árbol vigoroso y estable, el tronco y las raíces marcan la vida y expresividad de la colección de mesas de Francesc Rifé para Omelette Editions. La estructura lineal de la base se articula bajo un sistema de cruces, simétrico y preciso, que dialoga siempre con un sobre de forma curva.

[ENG] As though it were a vigorous and stable tree, the trunk and roots mark the life and expressiveness of the collection of tables by Francesc Rifé for Omelette Editions. The linear structure of the base is articulated under a system of crosses, symmetrical and precise, that hold a continuous dialogue with a curved top.



← Mesa Ox OM OX D120 con tablero en roble negro  
Ox table OM OX D120 with black oak top

← Mesa Ox OM OX D90 con tablero en roble negro  
Ox table OM OX D90 with black oak top





↑ Mesa Ox OM OX D90 con tablero en roble natural  
 Ox table OM OX D90 with natural oak top

→ Mesa Ox OM OX D120 con tablero en roble negro  
 Ox table OM OX D120 with black oak top





## NUA

### Información técnica Technical information

#### OM NUA. Mesa auxiliar / Side table

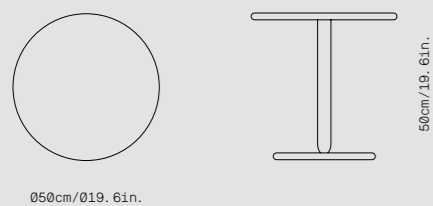

## DOWNTOWN

### Información técnica Technical information

#### OM DOWN D5030. Mesa auxiliar / Side table

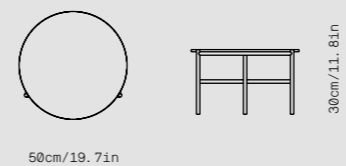

#### OM DOWN D5040. Mesa auxiliar / Side table

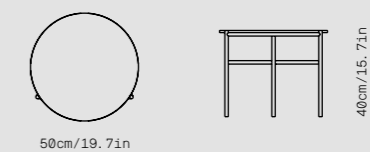

#### OM DOWN D5050. Mesa auxiliar / Side table

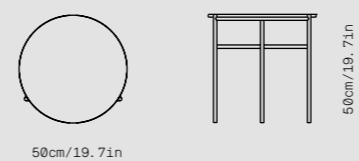

#### OM DOWN D85. Mesa auxiliar / Side table

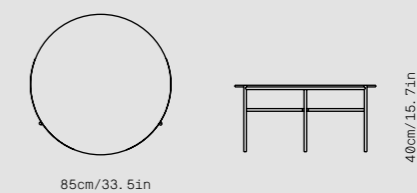

## DOMUS

### Información técnica Technical information

#### OM DOMUS 045. Mesa auxiliar / Side table

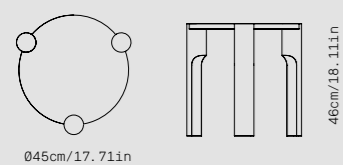

#### OM DOMUS 071. Mesa auxiliar / Side table

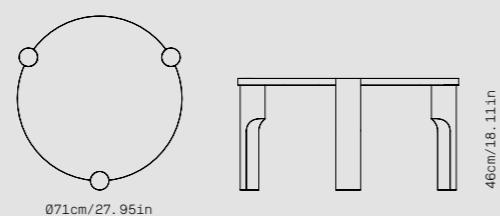

#### OM DOMUS 100. Mesa auxiliar / Side table

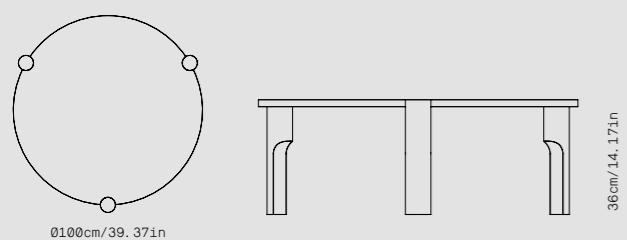

#### OM DOMUS 120. Mesa auxiliar / Side table

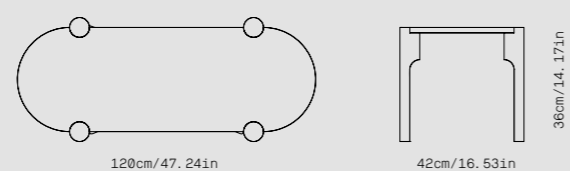



# BISON

## Información técnica Technical information

**OM BISON 045.** Mesa auxiliar / Side table

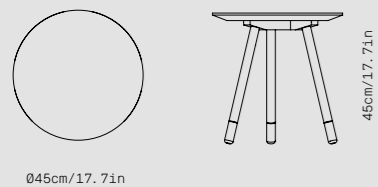

**OM BISON 071.** Mesa auxiliar / Side table

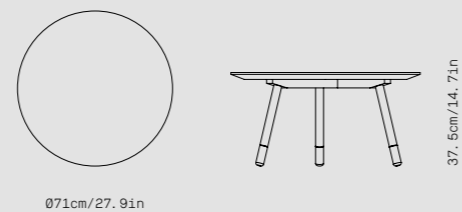

# OX

## Información técnica Technical information

**OM OX D90.**

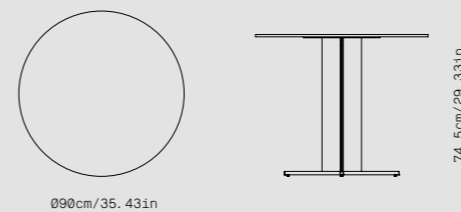

**OM OX D120.**

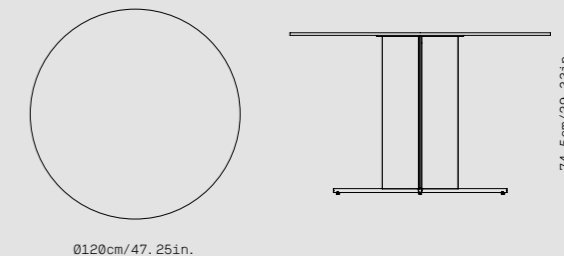

# FOLD

## Información técnica Technical information

**OM FOLD.** Mesa auxiliar / Side table

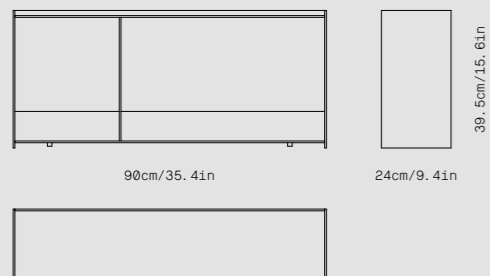

# Nua



Designed by

**Altherr Désile Park**

[ESP] Nua es una silla con una curvatura fluida en su respaldo y armoniosa en su simplicidad. Un asiento que, como el resto de los elementos de la colección, ha sido desarrollado con el objetivo de crear ambientes de interior perfectos, tanto en espacios residenciales como en contract, ya que se puede utilizar en diferentes rincones del hogar, pero también en restaurantes, salas de reuniones o oficinas. Nua lleva el concepto de confort, descanso, relajación, disfrute y de momentos de compartir del hogar al mundo hospitality, de la oficina y el retail y traspasa esa frontera más rígida propia de estos ámbitos.

[ENG] Nua is a chair with a fluid curvature in its backrest and harmonious in its simplicity. A seat that, like the rest of the collection elements, has been developed with the aim of creating perfect indoor environments, both in residential and contract spaces, as it can be used in different corners of the home, but also in restaurants, meeting rooms or offices. Nua takes the concept of comfort, rest, relaxation, enjoyment and moments of sharing from the home to the world of hospitality, office and retail and goes beyond the more rigid boundaries of these areas.



↑ Silla Nua OM NUA CH1 con patas y respaldo en fresno negro  
Nua chair OM NUA CH1 with legs and back in black ash

← Silla Nua OM NUA CH1 con patas y respaldo en roble natural  
Nua chair OM NUA CH1 with legs and back in natural oak





↑ Silla Nua OM NUA CH1 con patas y respaldo en fresno negro  
 Nua chair OM NUA CH1 with legs and back in black ash

→ Silla Nua OM NUA CH1 con patas y respaldo en roble natura  
 Nua chair OM NUA CH1 with legs and back in natural oak



# Alex



Designed by

# Isaac Piñeiro

[ESP] La idea de buscar una silla de simplicidad extrema con elementos estándar y alcanzar un grado de expresividad suficiente para dotarla de identidad fue el comienzo de este proyecto. Se trata de una silla informal que tiene una variedad de propósitos que van desde colocarla en áreas de recepción o espacios abiertos de una oficina a restaurantes u hogares. El nombre viene de Alexander Calder, punto de inspiración por sus esculturas y el punto de equilibrio que conseguía a través de las formas, las líneas el color y los diferentes materiales.

[ENG] The idea of looking for an extremely simple chair with standard elements and achieving a sufficient degree of expressiveness to give it an identity was the beginning of this project. It is an informal chair that has a variety of purposes ranging from being placed in reception areas or open spaces in an office to restaurants or homes. The name comes from Alexander Calder, a point of inspiration for his sculptures and the point of balance he achieved through shapes, lines, colour and different materials.



↑ Sillas Alex OM ALEX V2 con asiento y respaldo en roble natural  
Alex chairs OM ALEX V2 with seat and back in natural oak

← Sillas Alex OM ALEX V2 con asiento y respaldo en roble negro  
Alex chairs OM ALEX V2 with seat and back in black oak





Sillas Alex OM ALEX V1 con asiento y respaldo en roble humo, OM ALEX VT1 en roble natural, OM ALEX V2 en roble natural y OM ALEX VT2 en roble negro  
 Alex chairs OM ALEX V1 with seat and backrest in smoke oak, OM ALEX VT1 in natural oak, OM ALEX V2 in natural oak and OM ALEX VT2 in black oak.





↑ Sillas Alex OM ALEX V1 y OM ALEX V2 con asiento y respaldo en roble natural  
Alex chairs OM ALEX V1 and OM ALEX V2 with seat and backrest in natural oak

← Sillas Alex OM ALEX V2 con asiento y respaldo en roble natural  
Alex chairs OM ALEX V2 with seat and backrest in natural oak



# Alex Bistro



Designed by

## Isaac Piñeiro

[ESP] Alex Bistro es la hermana menor de Alex. Comparten la simplicidad extrema y una expresividad que la dota de identidad. Alex Bistro es una silla apilable pensada para espacios más compactos, ya sean contract o domésticos.

[ENG] Alex Bistro is the younger sister of Alex. They share an extreme simplicity and an expressiveness that gives it an identity. Alex Bistro is a stackable chair designed for more compact spaces, whether it be work or domestic.



↑ Silla Alex Bistro OM ALEX BISTRO V1  
con asiento y respaldo en roble negro  
Alex Bistro chair OM ALEX BISTRO V1  
with black oak seat and restback

← Silla Alex Bistro OM ALEX BISTRO VT1  
con respaldo en roble natural  
Alex Bistro chair OM ALEX BISTRO VT1  
with natural oak backrest.



↑ Silla Alex Bistro OM ALEX BISTRO V1  
 con asiento y respaldo en roble negro  
 Alex Bistro chair OM ALEX BISTRO V1  
 with black oak seat and backrest

→ Sillas Alex Bistro OM ALEX BISTRO VT1  
 con respaldo en roble natural  
 Alex Bistro chairs OM ALEX BISTRO VT1  
 with natural oak backrest







# Terra Wood

Designed by

# Isaac Piñeiro

[ESP] Terra series es una gran colección de asientos con diferentes acabados y tipos de pie. Terra Wood se distingue por el gran trabajo artesano e industrial de la ebanistería que hay detrás de cada pieza con detalles que la convierten en una pieza única. La rectitud de la estructura contrasta con el suave curvado de su carcasa que forman asiento y respaldo.

[ENG] Terra series is a large collection of seats with different finishes and foot types. Terra Wood is distinguished by the great craftsmanship and industrial joinery work behind each piece with details that make it a unique piece. The straightness of the structure contrasts with the soft curving of the shell that forms the seat and backrest.



↑ Silla Terra Wood OM TERRA WOOD V1  
con estructura y asiento en roble macizo natural  
Terra Wood chair OM TERRA WOOD V1  
with structure and seat in solid natural oak

← Silla Terra Wood OM TERRA WOOD VT1  
con estructura y asiento en roble macizo natural  
Terra Wood chair OM TERRA WOOD VT1  
with structure and seat in solid natural oak





↑ Silla Terra Wood OM TERRA WOOD V1  
con estructura y asiento en roble macizo natural  
Terra Wood chair OM TERRA WOOD V1  
with structure and seat in solid natural oak

→ Silla Terra Wood OM TERRA WOOD VT1  
con estructura y asiento en roble macizo natural  
Terra Wood chair OM TERRA WOOD VT1  
with structure and seat in solid natural oak







[ESP] Terra series es una gran colección de asientos con diferentes acabados y tipos de pie. Terra Metal se distingue por el gran trabajo artesano e industrial del metal que hay detrás de cada pieza, dos varillas transversales en los laterales hacen de esta silla una colección diferente. Su carcasa de asiento y respaldo queda al descubierto con el pie metálico.

[ENG] Terra series is a large collection of seats with different finishes and foot types. Terra Metal is distinguished by the great craftsmanship and industrial work of the metal behind each piece, two transverse rods on the sides make this chair a different collection. Its seat and back shell is exposed with the metal foot.



↑ Silla Terra Metal OM TERRA METAL VT1 con asiento en roble natural  
Terra Metal chair OM TERRA METAL VT1 with natural oak seat

← Silla Terra Metal OM TERRA METAL VT1 con asiento en roble natural  
Terra Metal chair OM TERRA METAL VT1 with natural oak seat





↑ Silla Terra Metal OM TERRA METAL V1 con asiento en roble negro  
Terra Metal chair OM TERRA METAL V1 with black oak seat

→ Silla Terra Metal OM TERRA METAL VT1 con asiento en roble natural  
Terra Metal OM TERRA METAL VT1 chair with natural oak seat







[ESP] Terra series es una gran colección de asientos con diferentes acabados y tipos de pie. Terra Swivel es una de las últimas incorporaciones a la serie, su pie giratorio realizado en aluminio inyectado con o sin ruedas nos da una gran versatilidad para diferentes espacios de trabajo o de hogar.

[ENG] Terra series is a large collection of seats with different finishes and foot types. Terra Swivel is one of the latest additions to the series, its swivel foot made of injected aluminum with or without wheels gives us a great versatility for different workspaces or home.



↑ Silla Terra Swivel OM TERRA SWIVEL VT1  
con estructura en negro y asiento en roble negro  
Terra Swivel chair OM TERRA SWIVEL VT1  
with black structure and black oak seat

← Silla Terra Swivel OM TERRA SWIVEL VT1  
con estructura en blanco y asiento en roble natural  
Terra Swivel chair OM TERRA SWIVEL VT1  
with white structure and natural oak seat



Sillas Terra Swivel OM TERRA SWIVEL VT1  
 con estructura en negro y asiento en roble negro  
 Terra Swivel chairs OM TERRA SWIVEL VT1  
 with black structure and black oak seat



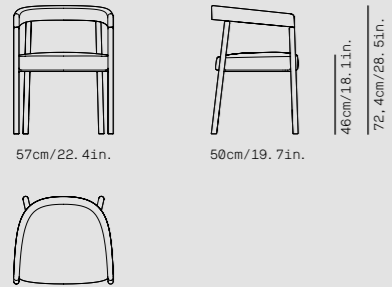
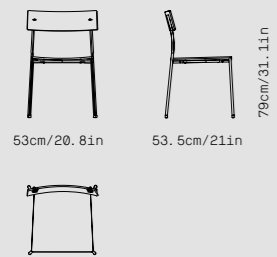
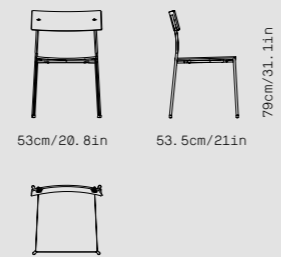
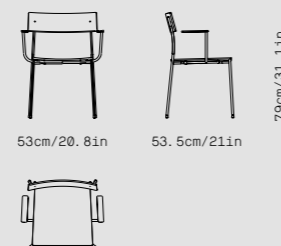
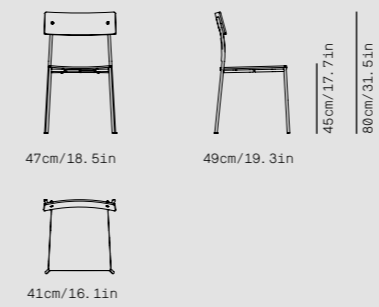
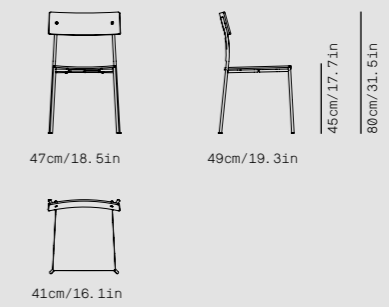
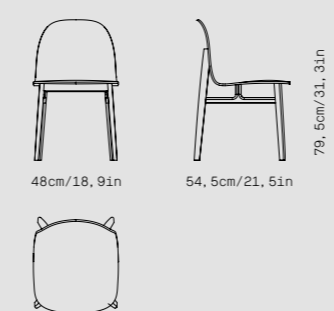
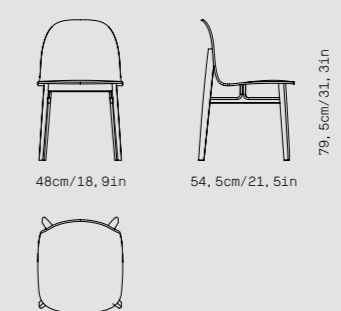

Sillas Terra OM TERRA SWIVEL V1R , OM TERRA VT1,  
OM TERRA METAL V1, OM TERRA METAL VT1,  
OM TERRA WOOD V1 y OM TERRA VT1  
Terra chairs OM TERRA SWIVEL V1R, OM TERRA VT1, OM TERRA  
METAL V1, OM TERRA METAL VT1, OM TERRA WOOD V1 and OM  
TERRA VT1.

**NUA****Información técnica**  
Technical information**OM NUA CH1. Asiento tapizado / Upholstered seat****ALEX****Información técnica**  
Technical information**OM ALEX V1. Sin tapizar / Unupholstered****OM ALEX V2. Sin tapizar / Unupholstered****OM ALEX VT1. Tapizada / Upholstered****OM ALEX VT2. Tapizada / Upholstered****ALEX BISTRO****Información técnica**  
Technical information**OM ALEX BISTRO V1. Sin tapizar / Unupholstered****OM ALEX BISTRO VT1. Tapizada / Upholstered****TERRA WOOD****Información técnica**  
Technical information**OM TERRA WOOD V1. Sin tapizar / Unupholstered****OM TERRA WOOD VT1. Tapizada / Upholstered**



# TERRA METAL

## Información técnica Technical information

### OM TERRA METAL V1. Sin tapizar / Unupholstered

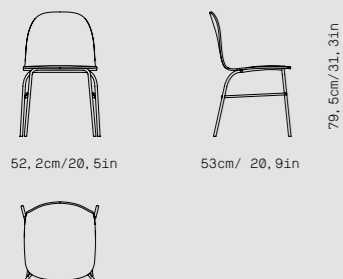

### OM TERRA METAL VT1. Tapizada / Upholstered



# TERRA SWIVEL

## Información técnica Technical information

### OM TERRA SWIVEL V1. Giratoria y sin tapizar / Swivel and upholstered

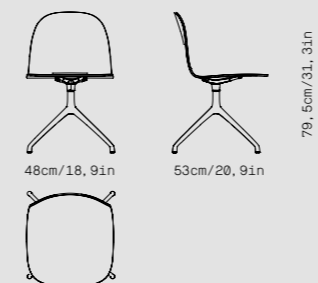

### OM TERRA SWIVEL VT1. Giratoria y tapizada / Swivel and upholstered

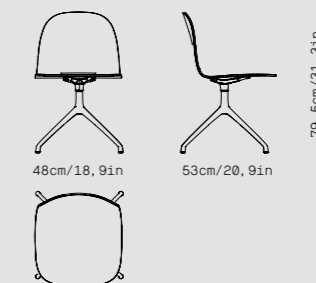

### OM TERRA SWIVEL V1R. Giratoria y sin tapizar con ruedas / Swivel and upholstered with wheels

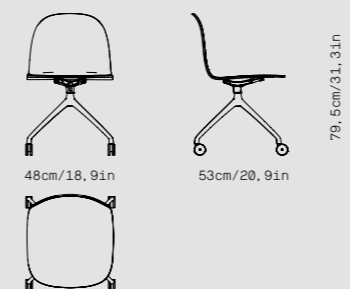

### OM TERRA SWIVEL VT1R. Giratoria y tapizada con ruedas / Swivel and upholstered with wheels

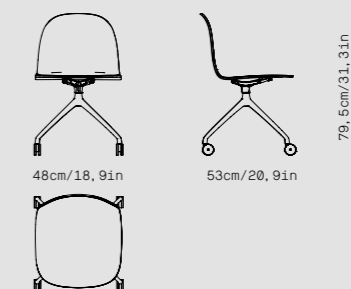

# Domus S65



[ESP] La colección Domus parte de una afirmación: "es una colección que me encantaría producirla yo mismo en un taller de madera por su sencillez y forma robusta". Un ejercicio de simplicidad, sobriedad y carácter, con dos detalles que lo caracterizan: el corte de la pata y su encuentro con el sobre. La colección de taburetes se presenta en dos alturas, 65 cm para barras de un metro como pueden ser las de cocina y altura 46 cm para diferentes espacios, desde hogar, hospitality o de trabajo.

[ENG] The Domus collection is based on a statement: "it is a collection that I would love to produce myself in a wood workshop because of its simplicity and robust form". An exercise in simplicity, sobriety and character, with two details that characterize it: the cut of the leg and its meeting with the top. The stool collection is available in two heights, 65 cm for one-meter bars such as those in the kitchen and 46 cm high for different spaces, from home, hospitality or work.



↑ Taburete Domus OM DOMUS S65  
con estructura en fresno macizo negro  
Domus stool OM DOMUS S65 with solid black ash structure

← Taburete Domus OM DOMUS S65  
con estructura en roble macizo natural  
Domus stool OM DOMUS S65 with solid natural ash structure



# Domus S46



Designed by

## Isaac Piñeiro

[ESP] La colección Domus parte de una afirmación: "es una colección que me encantaría producirla yo mismo en un taller de madera por su sencillez y forma robusta". Un ejercicio de simplicidad, sobriedad y carácter, con dos detalles que lo caracterizan: el corte de la pata y su encuentro con el sobre. La colección de taburetes se presenta en dos alturas, 65 cm para barras de un metro como pueden ser las de cocina y altura 46 cm para diferentes espacios, desde hogar, hospitality o de trabajo.

[ENG] The Domus collection is based on a statement: "it is a collection that I would love to produce myself in a wood workshop because of its simplicity and robust form". An exercise in simplicity, sobriety and character, with two details that characterize it: the cut of the leg and its meeting with the top. The stool collection is available in two heights, 65 cm for one-meter bars such as those in the kitchen and 46 cm high for different spaces, from home, hospitality or work.



↑ Taburete Domus S46 OM DOMUS S46  
con estructura en roble macizo natural  
Domus stool OM DOMUS S46 with solid natural ash structure

← Taburete Domus S46 OM DOMUS S46 con estructura en eoble  
macizo natural  
Domus stool OM DOMUS S46 with solid natural ash structure



[ESP] Terra series es una gran colección de asientos con diferentes acabados y tipos de pie. Terra Metal se distingue por el gran trabajo artesano e industrial del metal que hay detrás de cada pieza, dos varillas transversales en los laterales hacen de este taburete una colección diferente. Su carcasa de asiento y respaldo queda al descubierto con el pie metálico.

[ENG] Terra series is a large collection of seats with different finishes and types of feet. Terra Metal is distinguished by the great craftsmanship and industrial work of the metal behind each piece, two transverse rods on the sides make this stool a different collection. Its seat and back shell is exposed with the metal foot.



↑ Taburete Terra OM TERRA METAL S75 V1  
con asiento y respaldo en roble humo  
Terra stool OM TERRA METAL S75 V1  
with seat and back in smoked oak

← Taburete Terra OM TERRA METAL S65 VT1  
con asiento y respaldo en roble negro  
Terra stool OM TERRA METAL S65 VT1  
with seat and backrest in black oak





Taburetes Terra OM TERRA METAL S75 V1  
con asiento y respaldo en roble natural  
Terra stools OM TERRA METAL S75 V  
with seat and back in natural oak





[ESP] Alex Bistro taburete es la última incorporación a la colección Alex. Un taburete apilable pensado para espacios más compactos, ya sean contract o domésticos. Comparte como el resto de la colección una simplicidad extrema y una expresividad que la dota de identidad.

[ENG] Alex Bistro stool is the latest addition to the Alex collection. A stackable stool designed for more compact spaces, whether it be work or domestic. Like the rest of the collection, it shares an extreme simplicity and an expressiveness that gives it an identity.



↑ Taburete Alex Bistro OM ALEX STOOL V1  
con asiento y respaldo en roble natural  
Alex Bistro stool OM ALEX STOOL V1  
with seat and backrest in natural oak

← Taburete Alex Bistro OM ALEX STOOL V1  
con asiento y respaldo en roble natural  
Alex Bistro stool OM ALEX STOOL V1  
with seat and backrest in natural oak





↑ Taburete Alex Bistro OM ALEX STOOL V1  
con asiento y respaldo en roble negro  
Alex Bistro stool OM ALEX STOOL V1  
with black oak seat and back.

→ Taburetes Alex Bistro OM ALEX STOOL V1  
con asiento y respaldo en roble natural y  
Alex Bistro OM ALEX STOOL Vt1 roble negro  
Alex Bistro stool OM ALEX STOOL V1 with seat  
and back in natural oak and Alex Bistro stool  
OM ALEX STOOL Vt1 with black oak.



# DOMUS S65

Información técnica  
Technical information

## OM DOMUS S65.

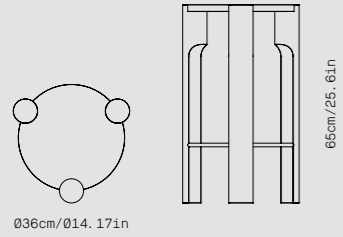

# DOMUS S46

Información técnica  
Technical information

## OM DOMUS S46.

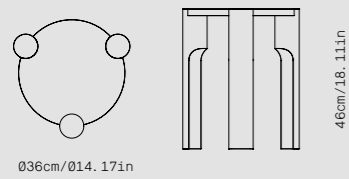

# TERRA

Información técnica  
Technical information

## OM TERRA METAL S65 V1. Sin tapizar / Unupholstered

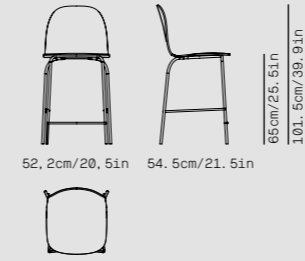

## OM TERRA METAL S75 V1. Sin tapizar / Unupholstered

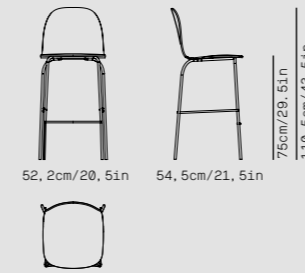

## OM TERRA METAL S65 VT1. Tapizada / Upholstered

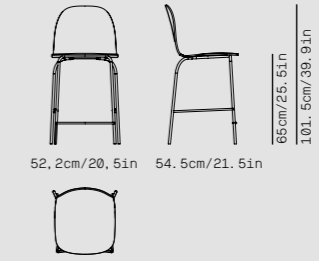

## OM TERRA METAL S75 VT1. Tapizada / Upholstered

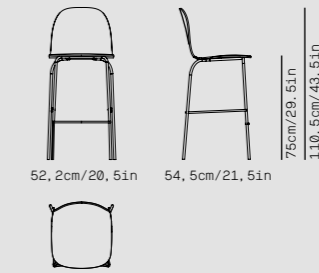

# ALEX BISTRO

Información técnica  
Technical information

## OM ALEX STOOL V1. Sin tapizar / Unupholstered

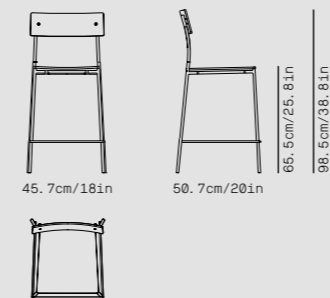

## OM ALEX STOOL VT1. Tapizada / Upholstered

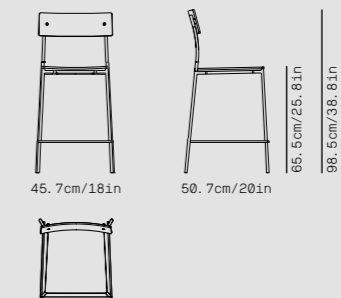



# Sente



Designed by

# Ana Motta

[ESP] Sente es un estante de aspecto sencillo y sofisticado. Un ejercicio de simplificación con el objetivo de llegar a la mínima esencia; una superficie de apoyo que puede hacer la veces de mesa auxiliar o simplemente de balda expositiva.

[ENG] Sente is a shelf with a simple and sophisticated appearance. An exercise in simplification with the aim of reaching the minimum essence; a support surface that can be used as a side table or simply as a display shelf.



↑ Accesorio Sente OM SENTE con estructura en rojo flúor  
Sente accessory OM SENTE with structure in flourescent red

← Accesorio Sente OM SENTE con estructura en negro  
Sente accessory OM SENTE with structure in black





↑ Accesorio Sente OM SENTE con estructura en negro  
Sente accessory OM SENTE with structure in black

→ Accesorio Sente OM SENTE con estructura en blanco  
Sente accessory OM SENTE with structure in white







[ESP] Vertical Mirror es un espejo de pared con forma geométrica rectangular. Nace de la interpretación de mover o desplazar los objetos sin necesidad de permanencia en un espacio, pudiendo estar un día en el salón y otro en la habitación principal. Diseñado para apoyar y fijar de pie contra la pared, de líneas simples y contemporáneas con una estructura metálica finalizada con dos pies de corcho que evitan el desplazamiento.

[ENG] Vertical Mirror is a wall mirror with a rectangular geometric shape. Born from the interpretation of moving or moving objects without the need for permanence in a space, being able to be one day in the living room and another in the main room. Designed to support and fix standing against the wall, simple and contemporary lines with a metal structure finished with two cork feet that prevent displacement.



↑ Espejo Vertical OM VM con estructura en blanco  
Vertical mirror OM VM with white structure

← Espejo Vertical OM VM con estructura en negro  
Vertical mirror OM VM with black structure





[ESP] Hang Mirror es un espejo para colgar a la pared con forma geométrica circular. Nace para dar continuación y ampliar la colección de espejos de la marca. Diseño de líneas simples y contemporáneas con una estructura metálica finalizada con un detalle en corcho.

[ENG] Hang Mirror is a mirror to hang on the wall with a circular geometric shape. Born to continue and expand the collection of mirrors of the brand. Design of simple and contemporary lines with a metal structure finished with a cork detail.



Espejo Hang OM HM con estructura en negro  
Hang mirror OM HM with black structure



# SENTE

Información técnica  
Technical information

## OM SENTE.



Ø25cm/Ø9.81in

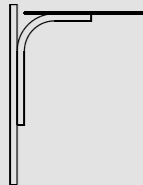

28cm/11in

37.5cm/14.81in

# VERTICAL

Información técnica  
Technical information

## OM VM.



62cm/24.4in

171cm/67.3in

# HANG

Información técnica  
Technical information

## OM HM.

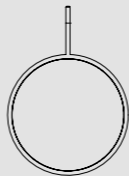

Ø62cm/Ø24.4in

87cm/34.2in



Savoye 8 Sofá Sofa



Majestic 16 Sofá Sofa



Must 24 Sofá Sofa



Masala 30 Sofá Sofa



Bolet 46 Butaca Lounge



Porta 52 Butaca Lounge



Alex 58 Butaca Lounge



Nua 62 Butaca Lounge



Savoye 68 Butaca Lounge



Majestic 72 Butaca Lounge



Masala 76 Butaca Lounge



Mole 84 Pouf



Savoye 88 Pouf



Majestic 90 Pouf



Nua 94 Mesa Table



Domus 98 Mesa Table



Downtown 102 Mesa Table



Bison 106 Mesa Table



Fold 108 Mesa Table



Ox 112 Mesa Table



Nua 120 Silla Chair



Alex 124 Silla Chair



Alex Bistro 130 Silla Chair



Terra Wood 134 Silla Chair



Terra Metal 138 Silla Chair



Terra Swivel 142 Silla Chair



Domus S65 152 Taburete Stool



Domus S46 154 Taburete Stool



Terra 156 Taburete Stool



Alex Bistro 160 Taburete Stool



Sente 166 Accesorio Accesory

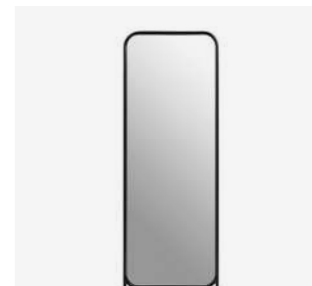

Vertical 170 Accesorio Accesory



Hang 173 Accesorio Accesory



**Concepto, dirección de arte, diseño editorial y visuales**  
/ Concept, art direction, editorial design and visuals  
**Inmenso Studio**

**Fotografía / Photography**  
**Cualiti Photo Studio**  
Eugeni Aguiló  
Pablo Santos

**Copyright 2024 © Omelette Editions**  
Todos los derechos reservados / All rights reserved



Fondo Europeo de  
Desarrollo Regional

*"Una manera de  
hacer Europa"*

UNIÓN EUROPEA

[www.omeletteeditions.com](http://www.omeletteeditions.com)



